



**Bapatla Engineering College:: Bapatla
(Autonomous)**

Bapatla Engineering College

(Autonomous)

BAPATLA



**Department of Electrical & Electronics Engineering
POWER SYSTEMS LAB(18EEL72) MANUAL
R18 REGULATIONS**



Bapatla Engineering College:: Bapatla

(Autonomous under Acharya Nagarjuna University)

(Sponsored by Bapatla Education Society)

BAPATLA-522102, Guntur District, A.P.

www.becbapatla.ac.in



Bapatla Engineering College:: Bapatla (Autonomous)

Vision of the Institute

To build centers of excellence, impart high quality education and instill high standards of ethics and professionalism through strategic efforts of our dedicated staff, which allows the college to effectively adapt to the ever-changing aspects of education.

To empower the faculty and students with the knowledge, skills and innovative thinking to facilitate discovery in numerous existing and yet to be discovered the fields of engineering, technology and inter-disciplinary endeavors.

Mission of the Institute

To impart the quality education at par with global standards to the students from all over India and in particular those from the local and rural areas.

To maintain high standards so as to make them technologically competent and ethically strong individuals who shall be able to improve the quality of life and economy of our country.

Vision of the Department

The Department of Electrical & Electronics Engineering will provide programs of the highest quality to produce globally competent technocrats who can address challenges of the millennium to achieve sustainable socio - economic development.

Mission of the Department

- M1. To provide quality teaching blended with practical skills.
- M2. To prepare the students ethically strong and technologically competent in the field of Electrical and Electronics Engineering.
- M3. To motivate the faculty and students in the direction of research and focus to fulfill social needs.

Program Educational Objectives (PEOs)

PEO1. To have a strong foundation in the principles of Basic Sciences, Mathematics and Engineering to solve real world problems encountered in modern electrical engineering and pursue higher studies/placement/research.

PEO2. To have an integration of knowledge of various courses to design an innovative and cost effective product in the broader interests of the organization & society.



Bapatla Engineering College:: Bapatla (Autonomous)

PEO3. To have an ability to lead and work in their profession with multidisciplinary approach, cooperative attitude, effective communication and interpersonal skills by participating in team oriented and open ended activities.

Program Outcomes:

Engineering graduates will be able to:

PO1. Engineering knowledge: Apply the knowledge of mathematics, science, engineering fundamentals and an engineering specialization to the solution of Electronics and Instrumentation Engineering. problems.

PO2. Problem analysis: Identify, formulate, research literature and analyze complex engineering problems reaching, substantiated conclusions using first principles of mathematics, natural sciences and engineering sciences.

PO3. Design/development of solutions: Design solutions for problems in the field of Electronics and Instrumentation Engineering and design system components or processes that meet the specified needs with appropriate consideration for public health and safety and the cultural, societal and environmental considerations.

PO4. Conduct investigations of complex problems: Use research-based knowledge and research methods including design of experiments, analysis and interpretation of data and synthesis of the information to provide valid conclusions.

PO5. Modern tool usage: Create, select, and apply appropriate techniques, resources and modern engineering and IT tools including prediction and modeling to complex engineering activities with an understanding of the limitations.

PO6. The Engineer and Society: Apply reasoning informed by the contextual knowledge to assess societal, health, safety, legal and cultural issues and the consequent responsibilities relevant to the professional engineering practice.

PO7. Environment and Sustainability: Understand the impact of the Electronics and Instrumentation Engineering solutions in societal and environmental contexts, and demonstrate the need for sustainable development.



Bapatla Engineering College:: Bapatla (Autonomous)

PO8. Ethics: Apply ethical principles and commit to professional ethics and responsibilities and norms of the engineering practice.

PO9. Individual and Team work: Function effectively as an individual and as a member or leader in diverse teams and in multidisciplinary settings.

PO10. Communication: Communicate effectively on Electronics and Instrumentation Engineering activities with the engineering community and with the society at large, such as being able to comprehend and write effective reports and design documentation, make effective presentations and receive clear instructions.

PO11. Project management and Finance: Demonstrate knowledge and understanding of the engineering and management principles and apply these to one's own work as a member and leader in a team to manage projects in a multidisciplinary environment.

PO12. Life-long Learning: Recognize the need for and have the preparation and ability to engage in independent and life-long learning in the broadest context of technological change.

Program Specific Outcomes (PSO's)

PSO1: The Electrical and Electronics Engineering graduates are capable of applying the Knowledge of mathematics and sciences in modern power industry.

PSO2: Analyse and design efficient systems to generate, transmit, distribute and utilize electrical energy to meet social needs using power electronic systems.

PSO3: Electrical Engineers are capable to apply principles of management and economics for providing better services to the society with the technical advancements in renewable and sustainable energy integration.



Bapatla Engineering College:: Bapatla (Autonomous)

POWER SYSTEMS LAB

IV B. Tech-VII Semester (Code: 18EEL72)

Lectures	0	Tutorials	0	Practical	3	Credits	1
Continuous Internal Evaluation			50	Semester End Examination (3 hours)		5	

Prerequisites: **Mathematics, PDS, RES.**

Course Objective: To make the students

- 1:** Analyze the performance of transmission line
- 2:** Able to do Experiment in various protection of generator, feeder and transmission line using relays and circuit breakers.
- 3:** Able to conduct testing about the various electromagnetic Relays
- 4:** Be competent in use of static and digital relays.
- 5:** Develop simulation model for RES

Course Outcomes: Students will be able to

- CO1:** Analyze the performance of transmission line
- CO2:** Examine various protection of generator, feeder and transmission line using relays and circuit breakers.
- CO3:** Execute testing about the various electromagnetic Relays
- CO4:** Competent in use of static and digital relays.
- CO5:** Analyze simulation model for RES



Bapatla Engineering College:: Bapatla (Autonomous)

POWER SYSTEMS LAB

IV B. Tech-VII Semester (Code: 18EEL72)

Lectures	0	Tutorials	0	Practical	3	Credits	1
Continuous Internal Evaluation			50	Semester End Examination (3 hours)		5	

LIST OF EXPERIIMENTS:

1. Determination of ABCD parameters/ Regulation and efficiency of transmission line model.
2. Characteristics of IDMT over current relay/over voltage electromagnetic relay.
3. Finding the sequence impedance of 3-phase synchronous machine.
4. Reactive power compensation using tap changing transformer.
5. Surge impedance loading of transmission line model.
6. Find cable fault using cable fault location/Find hotspots using thermal image camera.
7. To study characteristics of MCB and HRC Fuse.
8. Test to find out polarity, ration and magnetization characteristics of CT and PT.
9. Study on (i) on load Time Delay Relay (ii) off load Time Delay Relay.
10. Characteristics of over current/earth fault using numerical relay.
11. Characteristics of numerical distance relay.
12. Characteristics of numerical differential relay.
13. Identifying and Measuring the parameters of solar PV module in the field.
14. Series and parallel connection of PV Modules.
15. Study of Solar/ Wind turbine generator power plant.

NOTE: Minimum 10experiments should be conducted.



Bapatla Engineering College:: Bapatla (Autonomous)

ABCD PARAMETERS OF TRANSMISSION LINE

AIM:

To study the performance of a transmission line. Also compute its ABCD parameters.

APPARATUS:

S. No.	Apparatus	Range
1	Transmission Line Model	Different π sections
2	Power Analyzer	-
3	Voltmeter	0-750V AC
4	Ammeter	0-20A AC
5	Variac	1 ϕ 0-230V AC
7	Patch Cords/Connecting wires	As required

THEORY:

ABCD Parameter are widely used in analysis of power transmission engineering where they will be turned as “Generalized circuit parameter” ABCD parameters are also called as Transmission parameter. It is conventional to designate the input port as sending end and the output port as receiving end while representing ABCD parameter.

We know that,

$$V_S = A V_R + B I_R \quad \text{-----} \quad (1)$$

$$I_S = C V_R + D I_R \quad \text{-----} \quad (2)$$

At open circuit conditions, we get

$$A = V_s/V_r \quad \text{when } I_r = 0 \quad (3)$$

$$C = I_s/V_r \quad \text{when } I_r = 0 \quad (4)$$

At short circuit conditions, we get

$$B = V_s/I_r \quad \text{when } V_r = 0 \quad (5)$$

$$D = I_s/I_r \quad \text{when } V_r = 0 \quad (6)$$

$$AD - BC = 1 \quad \text{-----} \quad (7)$$



Bapatla Engineering College:: Bapatla (Autonomous)

The above method can be used for short transmission line.

For medium or long transmission line,

Open circuiting the receiving end of the line, the open circuit impedance Z_{oc} is measured at the sending end as

$$Z_{OC} = A/C \dots\dots\dots (8)$$

Short circuiting the load end of the line, the short circuit impedance Z_{sc} is measured at the sending end as

$$Z_{sc} = B/A \dots\dots\dots (9)$$

For a symmetrical network,

$$A = D, \dots\dots\dots (10)$$

For a passive network,

$$AD - BC = 1 \dots\dots\dots (11)$$

Substituting equation (10) in equation (11),

$$A^2 - BC = 1 \dots\dots\dots (12)$$

CIRCUIT DIAGRAM: -

For open circuit test

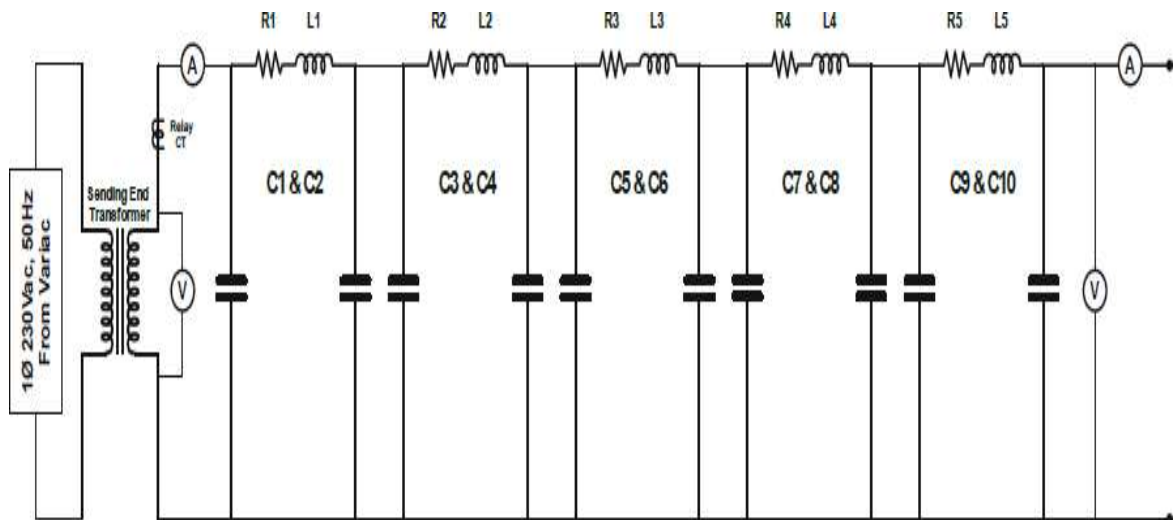



Bapatla Engineering College:: Bapatla (Autonomous)

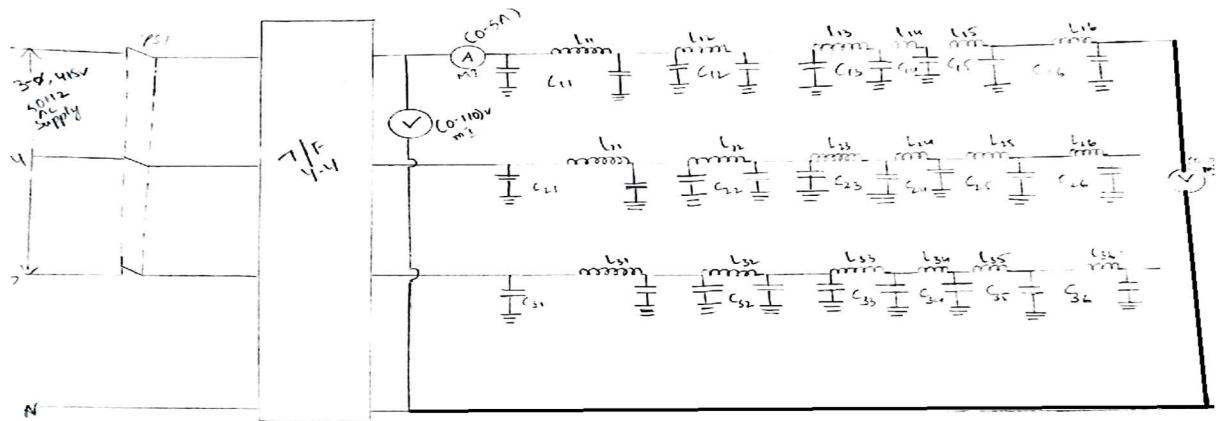

Circuit for open circuit test for calculating A and C value

For short circuit test

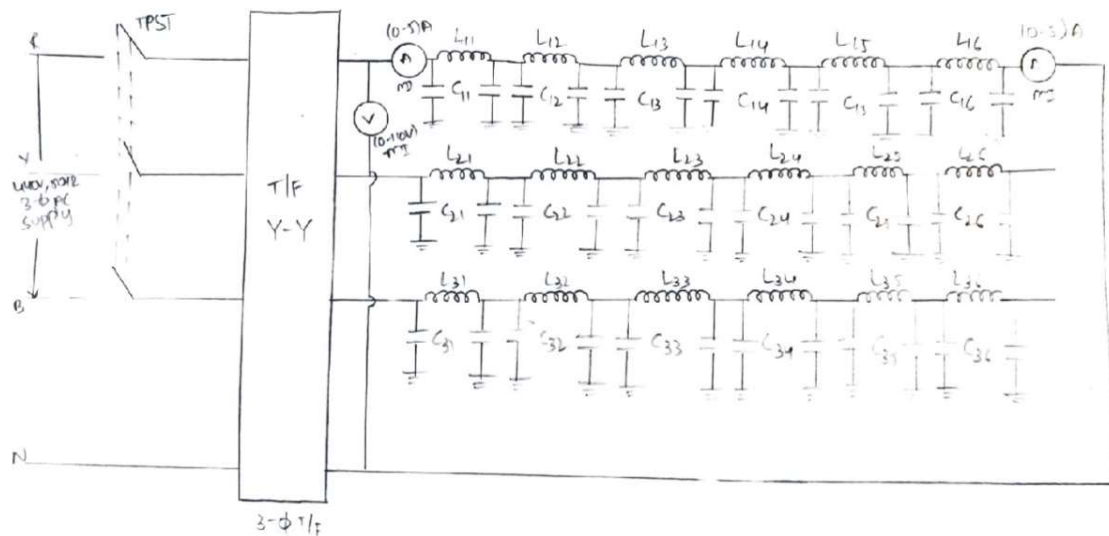
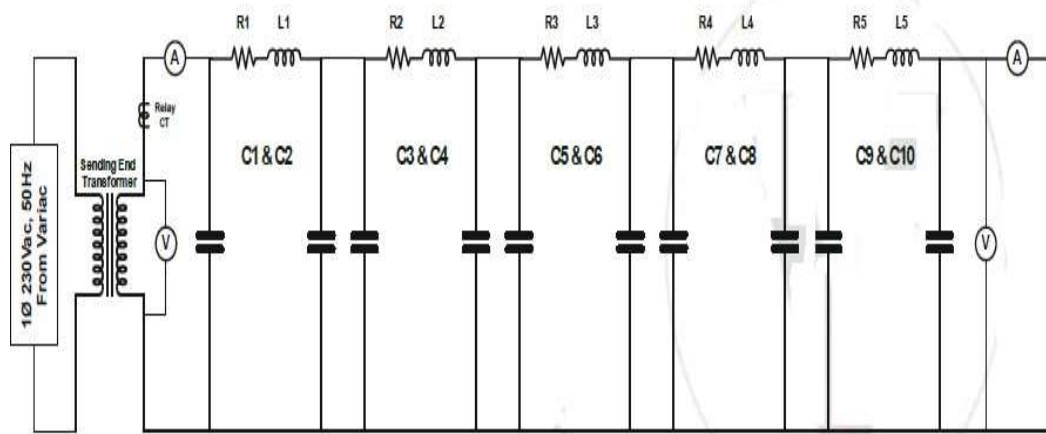

Circuit for short circuit test calculating B and D values



Bapatla Engineering College:: Bapatla (Autonomous)

PROCEDURE:

1. To find out A and C parameters connect voltage supply of 220V to sending end and opencircuit receiving end.
2. Observe the voltage of V_s , I_s and V_r with the help of voltmeter and ammeters in the experimental kit.
3. To find out B and D receiving end is short circuited and supply of 220V is given to sendingend.
4. Observe the voltage of V_s , I_s and I_r . The Calculated A, B, C, D Parameters are
5. A=
B=
C=
D=

TABULAR COLUMN:

Open Circuit:-

S.No	VS	IS	VR	A=VS/VR	C=IS/VR

Short Circuit:-

S.No	VS	IS	VR	B=VS/IR	D=IS/IR

RESULT:



Bapatla Engineering College:: Bapatla (Autonomous)

EFFICIENCY AND REGULATION OF A TRANSMISSION LINE

AIM:

To determine the performance of the transmission line by calculating its efficiency and regulation

APPARATUS:

S.No	Apparatus	Range
1.	Transmission line model	Different π sections
2.	Power analyzer	
3.	Voltmeter	0-750V AC
4.	Ammeter	0-20A AC
5.	Variac	1 ϕ 0-230V AC
6.	Patch Cords/Connecting wires	As required

THEORY

The performance of a power system is mainly dependent on the performance of the transmission lines in the system. It is necessary to calculate the voltage, current and power at any point on a transmission line provided the values at one point are known.

The transmission line performance is governed by its four parameters - series resistance and inductance, shunt capacitance and conductance. All these parameters are distributed over the length of the line. The insulation of a line is seldom perfect and leakage currents flow over the surface of insulators especially during bad weather. This leakage is simulated by shunt conductance. The shunt conductance is in parallel with the system capacitance. Generally the leakage currents are small and the shunt conductance is ignored in calculations.

Performance of transmission lines is meant the determination of efficiency and regulation of lines. The efficiency of transmission lines is defined as

$$\% \text{ efficiency } (\eta) = \frac{\text{Power delivered at the receiving end}}{\text{Power sent from the sending end}} * 100$$



Bapatla Engineering College:: Bapatla (Autonomous)

The end of the line where load is connected is called the receiving end and where source of supply is connected is called the sending end.

$$\% \text{ regulation} = \frac{|V_r(\text{No Load})| - |V_r(\text{Load})|}{|V_r(\text{Load})|} * 100$$

CIRCUIT DIAGRAM:

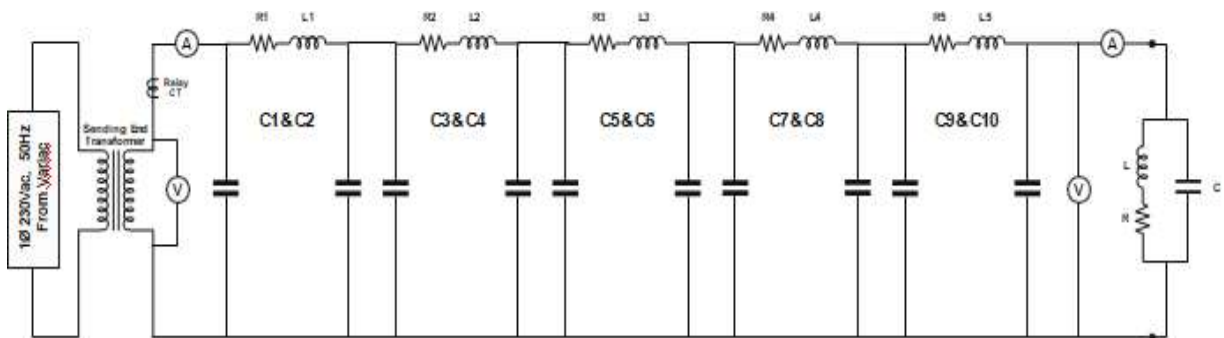

Circuit for loading at receiving end

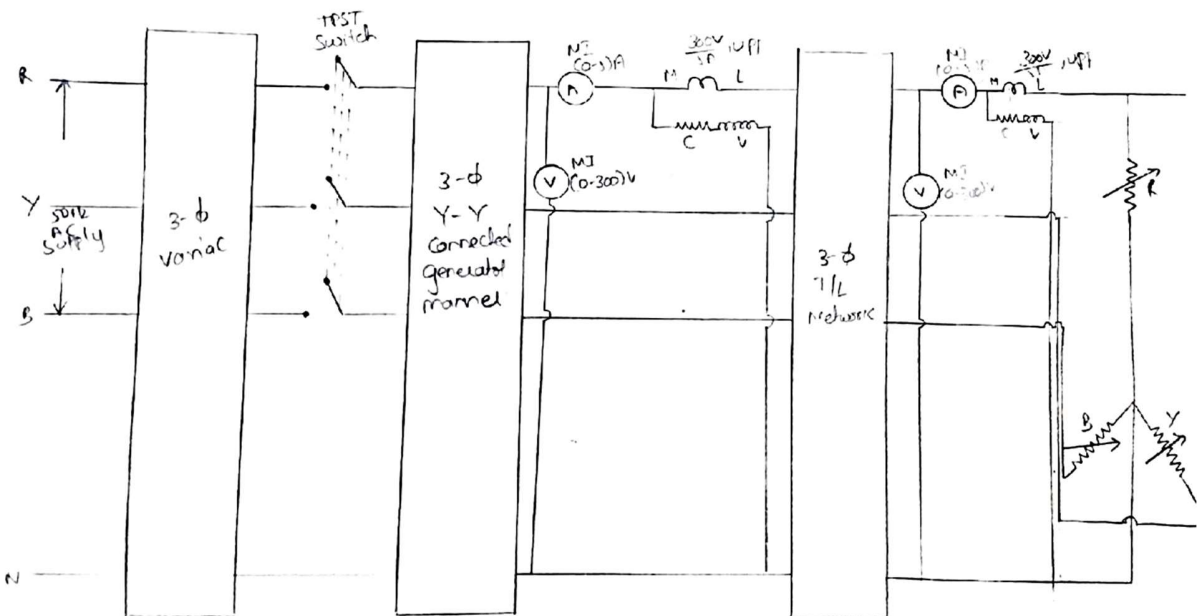



Bapatla Engineering College:: Bapatla (Autonomous)

GRAPHS:

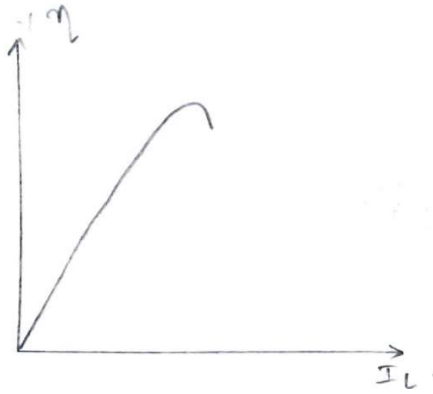

Efficiency

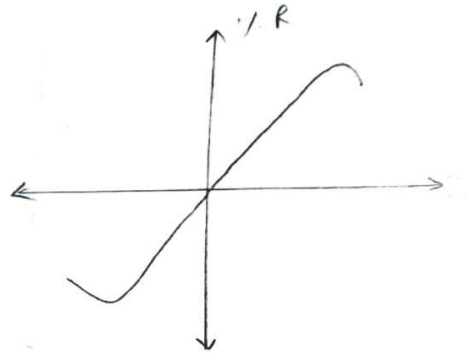

(b) Regulation

RESULT:



Bapatla Engineering College:: Bapatla (Autonomous)

CHARACTERISTICS OF OVER CURRENT RELAY

AIM:

To draw the performance of over current relay

APPARATUS:

S.NO	Name of the apparatus	Range	Type	Quantity
1.	Overcurrent relay	-	-	1
2.	1- ϕ variac	230 V/5 A	Iron core	1
3.	Electric probes	-	-	Required

CIRCUIT DIAGRAM:

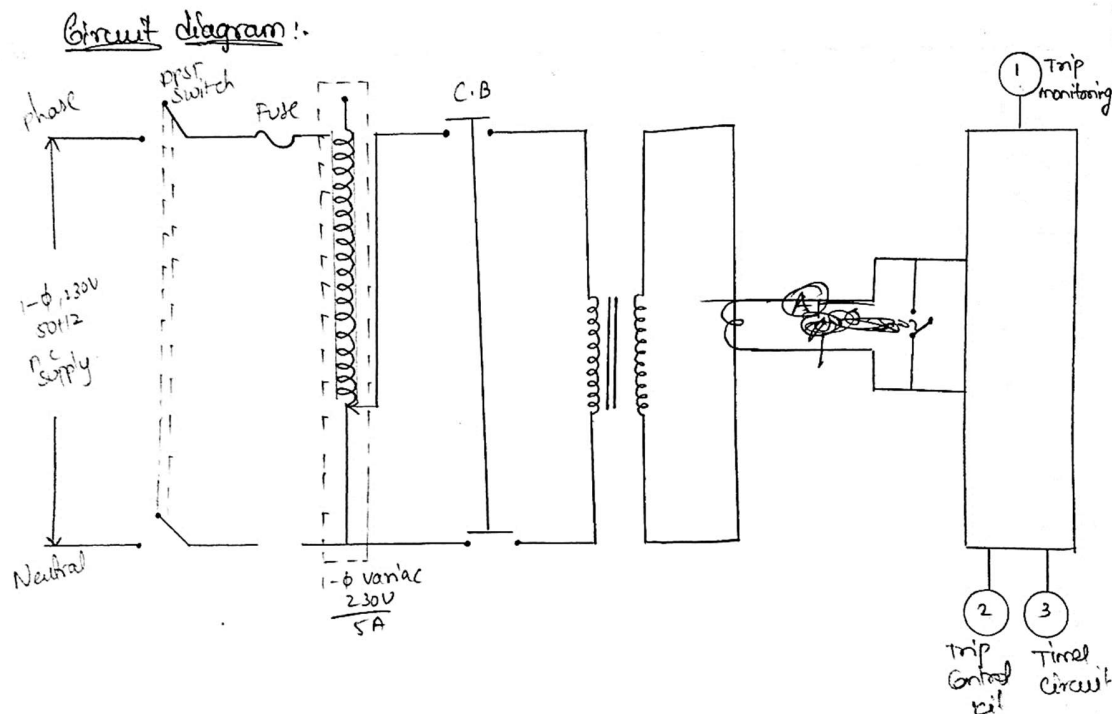

PROCEDURE:

1. Connections are made as per the circuit diagram.
2. Make sure that switches are in off position.
3. Make sure that rotary switch in set mode.



Bapatla Engineering College:: Bapatla (Autonomous)

4. Switch on the C.B and apply above rated current.
5. Switch off the C.B and put rotary switch in test mode wait until relay in test mode and again switch on the C.B.
6. Now note down the applied current and tripping time.
7. Reset the C.B and tripping time.
8. Now again put the rotary switch in set mode and switch on the C.B.
9. Apply the next value of over current and continue the above procedure until it's reaches its saturation position (until the tripping time remains same).

TABULAR FORM:

SI.NO	Fault current (Amp)	Tripping Time (sec)

MODEL GRAPH

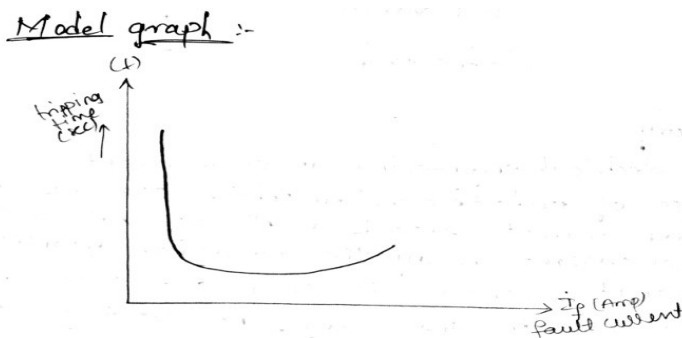

PRECAUTIONS:

1. Avoid loose connections.
2. Wait until the p.s.m stops and then note down the reading.

RESULT:

The characteristics of over current relay is drawn.



Bapatla Engineering College:: Bapatla (Autonomous)

CHARACTERISTICS OF OVER VOLTAGE RELAY

AIM:

To draw the characteristics of over voltage relay.

APPARATUS:

Sl.NO	Name of the apparatus	Range	Type	Quantity
1.	Overvoltage relay	-	-	1
2.	1- ϕ Variac	230V/(0-270)V/5 A	Iron core	1
3.	Connecting wires	-	-	Required

CIRCUIT DIAGRAM:

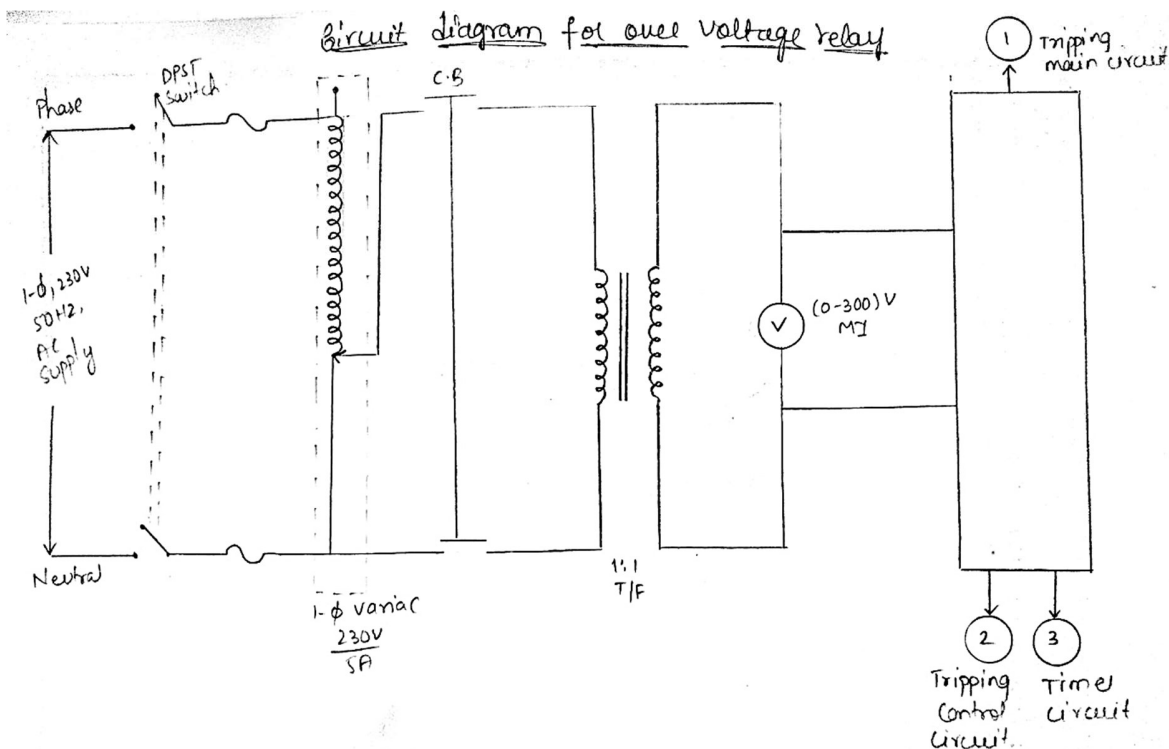

PROCEDURE:

1. Connections are Made as per the circuit diagram.
2. Make sure that switches are in off position.



Bapatla Engineering College:: Bapatla (Autonomous)

3. Make sure that rotary switch in set mode.
4. Switch on MCB and make sure that all the meters are energized and then apply above rated voltage.
5. Switch off the C.B and put rotary switch in test mode and wait until the relay in rest mode.
6. Note down again the switch on the C.B , now reading must be taken as applied voltage , and tripping time.
7. Reset the C.B and tripping time.
8. Again put the rotary switch in set mode and switch on C.B and apply next value of over voltage.
9. Continue the procedure till graph reaches the saturation.

TABULAR FORM:

S.NO	Voltage (v)	Time (sec)

Model Graph:

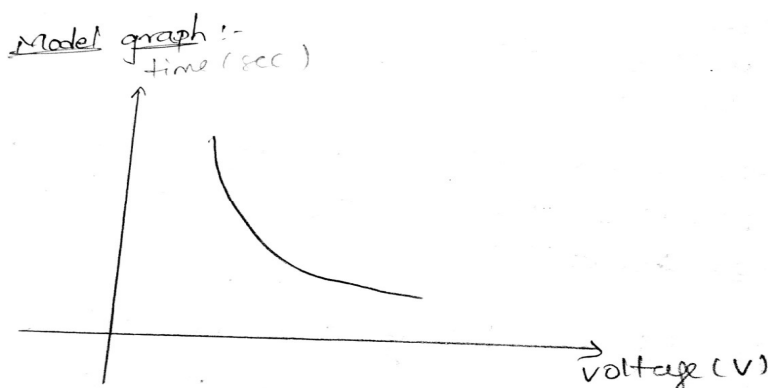

PRECAUTIONS:

1. Avoid loose connections.
2. Reading should be taken without any parallax errors.

RESULTS:

The characteristics of over voltage relay is drawn.



Bapatla Engineering College:: Bapatla (Autonomous)

SEQUENCE IMPEDANCE OF AN ALTERNATOR

AIM:

To find the sequence impedance of an Alternator.

APPARATUS:

S.NO	Name of Apparatus	Type	Range	Quantity
1.	Voltmeter	MI	(0-30)V	1
		MI	(0-600)V	1
2.	Ammeter	MI	(0-10)A	1
		MI	(0-3)A	1
3.	Rheostat	WW	50 ohm/5 A	1
			350 ohm/2A	1
			600 ohm/2A	1
4.	Tachometer	Digital	(0-900) rpm	1
5.	Probes	-	-	Required

CIRCUIT DIAGRAM:1

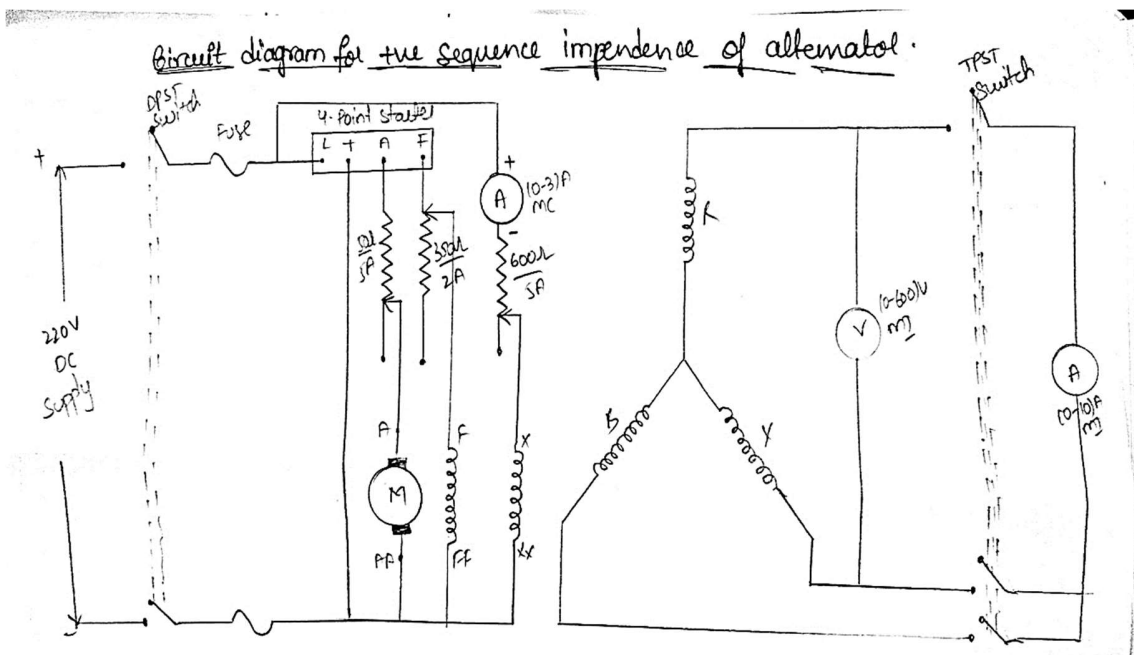



Bapatla Engineering College:: Bapatla (Autonomous)

CIRCUIT DIAGRAM:2

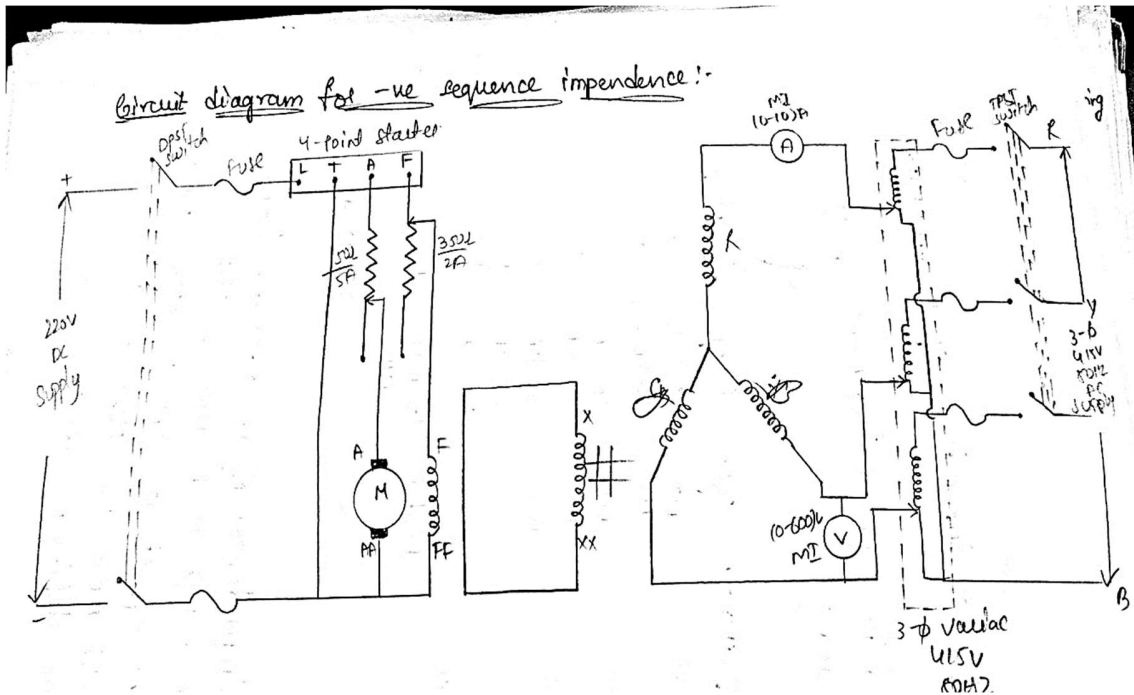

CIRCUIT DIAGRAM:3

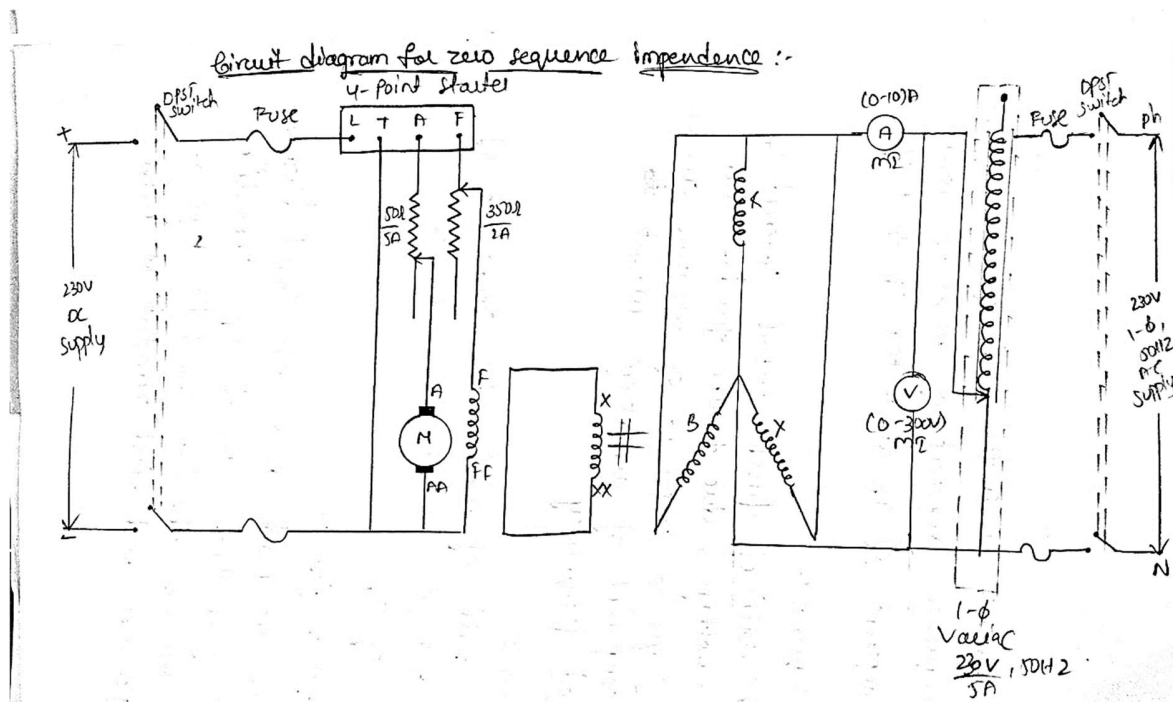



Bapatla Engineering College:: Bapatla (Autonomous)

PROCEDURE:

Procedure for o.c test:

1. Connections are made as per the circuit diagram.
2. Supply is given to the circuit after connection.
3. Initially Armature rheostat should be kept at max position and field rheostat at min position.
4. Start the motor with the help of 4-point starter and bring the machine to rated speed by varying armature rheostat and field rheostat if necessary.
5. Now vary the alternator field rheostat up to rated voltage and note down the reading of voltage and field current of alternator o.c.
6. After conducting o.c test bring the alternator rheostat to initial position and close the TPST switch.

Short Circuit Test:

1. Then vary the Excitation of alternator rheostat up to rated short circuit current.
2. Note down the value of I_f and I_{sc} .
3. Calculate the +Ve sequence impedance by using the formula , $Z_1 = V_{oc}/\phi/I_{sc}$.

Procedure for –Ve Sequence impedance:

1. Connections are made as per the circuit diagram.
2. Short circuit the field of alternator before doing the experiment.
3. Apply the reduced voltage to alternator by varying the 3- ϕ Variac until the ammeter reads rated current.
4. Note down the reading of voltmeter and ammeter .
5. Calculate the negative sequence impedance.

$$Z_2 = V\sqrt{3}/I$$

Procedure for Zero-Sequence impedance:

1. Connections are made as per the circuit diagram.
2. Keep the field of alternator in short circuit .
3. Apply the rated voltage to armature by using 1- ϕ variac.
4. Until the armature reads rated current (9A)
5. Note down the reading of voltmeter and ammeter.
6. Calculate the Zero Sequence impedance.

$$Z_0 = 3V_0/I_0$$



Bapatla Engineering College:: Bapatla (Autonomous)

GRAPH DIAGRAM:

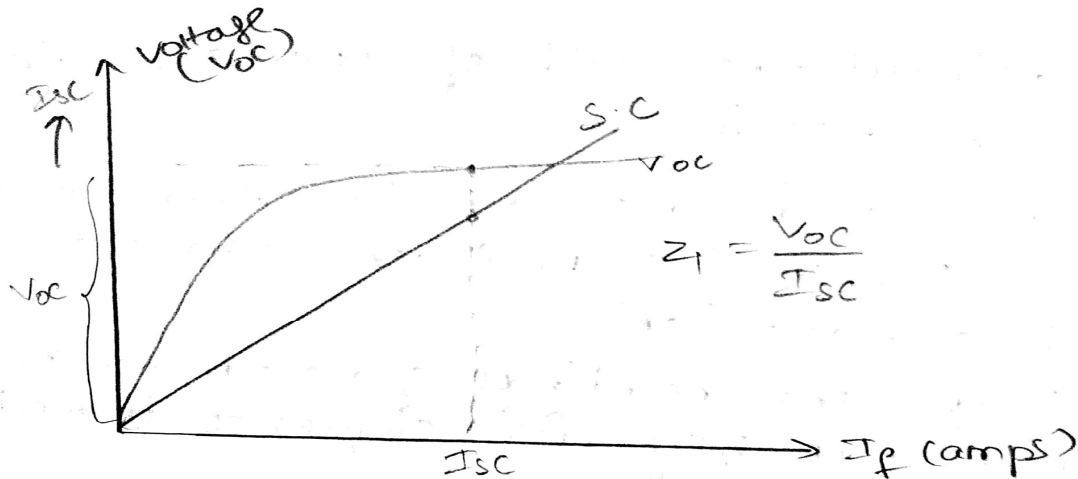

PRECAUTIONS:

1. Connections are made as per circuit diagram.
2. connections should be tight.
3. Reading should be taken without parallax error.

RESULT:

The Positive, Negative & Zero Sequence impedance were found.

$Z_1 =$ from table

$Z_1 =$ from graph

$Z_2 =$ ohm

$Z_0 =$ ohm



Bapatla Engineering College:: Bapatla (Autonomous)

REACTIVE POWER COMPENSATION USING TAP CHANGING TRANSFORMER

AIM:

To study of voltage improvement by reactive power compensation using tap changing transformer.

APPARATUS:

S.NO	Apparatus	Range
1.	Transmission Line Model	Different π section
2.	Power Analyzer	-
3.	Voltmeter	0-750V AC
4.	Ammeter	0-20A AC
5.	Variac	1- \emptyset , 0-230V AC
6.	Patch Cords/Connecting wires	As required

THEORY:

Tap changing in Transformers is a normal fact that increases in load lead to decrease in the supply voltage. Hence the voltage supplied by the transformer to the load must be maintained within the prescribed limits. This can be done by changing the transformer turns ratio. The taps are leads or connections provided at various points on the winding. The turns ratio differs from one tap to another and hence different voltages can be obtained at each tap.

Need for system voltage control

- System voltage control is essential for:
- Adjusting the terminal voltage of consumer within the prescribed limits
- Adjustment of voltage based on change in load.
- In order to control the real and reactive power.
- For varying the secondary voltage based on the requirement.

Types of taps

Taps may be principal, positive or negative. Principal tap is one at which rated secondary voltage can be obtained for the rated primary voltage. As the name states positive and negative taps are those at which secondary voltage is more or less than the principle tap



Bapatla Engineering College:: Bapatla (Autonomous)

CIRCUIT DIAGRAM:

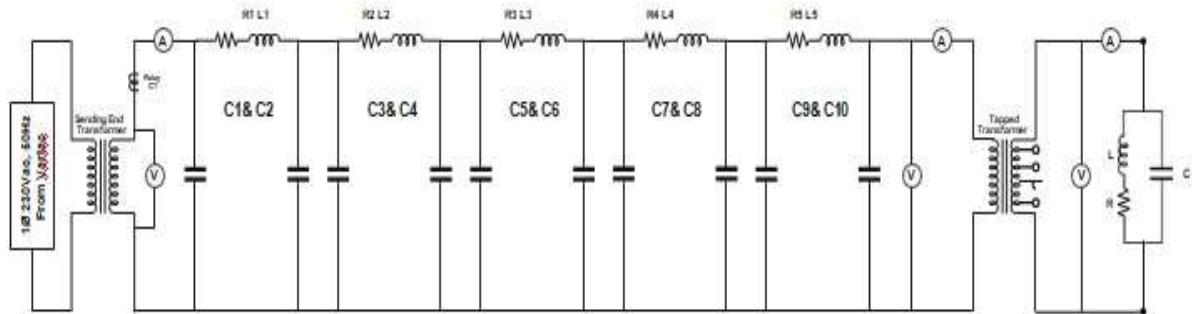

PROCEDURE:

1. Connect mains cable to 230VAC, Single phase supply with proper earth connection.
2. Keep MAINS MCB in OFF position and the variac in Zero position.
3. Make the connection as per circuit diagram shown in fig (9). Receiving is connected through the meter to tap changing transformer and to the load. (if required use variac-2 to have control over input to the tap changing transformer)
4. Switch on MAINS+CONTROL MCB. All the meters will glow.
5. Put both the relays to UNHEALTHY state.
6. Select the values of line inductance and capacitance as required.
7. Press CB-1 ON push button.
8. Set the voltage of sending end such that the receiving end voltage is 220V
9. Press CB-2 ON and CB-3 ON push button.
10. Apply load using the RLC Unit provided.
11. Observe the voltage at the load end. If $V < 220V$ then decrease it by reduce the value of tapped output.

TABULAR COLUMN:

S.NO	Sending End		Receiving End		
	Voltage (V_S)	Current (I_S)	Voltage (V_R)	Current (I_R)	Reactive power
1.					
2.					
3.					

RESULT:



Bapatla Engineering College:: Bapatla (Autonomous)

SURGE IMPEDANCE LOADING

AIM:

To study Surge Impedance Loading (SIL) of a transmission line.

APPARATUS:

S.NO	Apparatus	Range
1.	Transmission Line Model	Different π section
2.	Power Analyzer	-
3.	Voltmeter	0-750V AC
4.	Ammeter	0-20A AC
5.	Variac	1- ϕ , 0-230V AC
6.	Patch Cords/Connecting wires	As required

THEORY:

Surge Impedance Loading of a line is the power transmitted when it is transmitted through a resistance equal to surge impedance.

$$I^2 \omega L = V^2 \omega C$$

$$\frac{V}{I} = \sqrt{\frac{L}{C}} = Z_n$$

Z_n is natural impedance and surge impedance of the line.

$$P_0 = \frac{V^2}{Z_n}$$

CIRCUIT DIAGRAM:

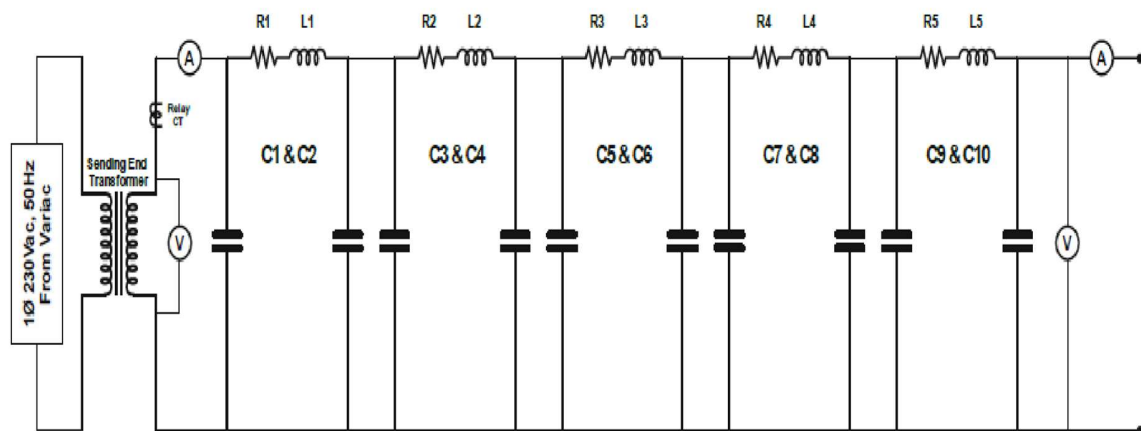

Fig.1. Circuit for open circuit test



Bapatla Engineering College:: Bapatla (Autonomous)

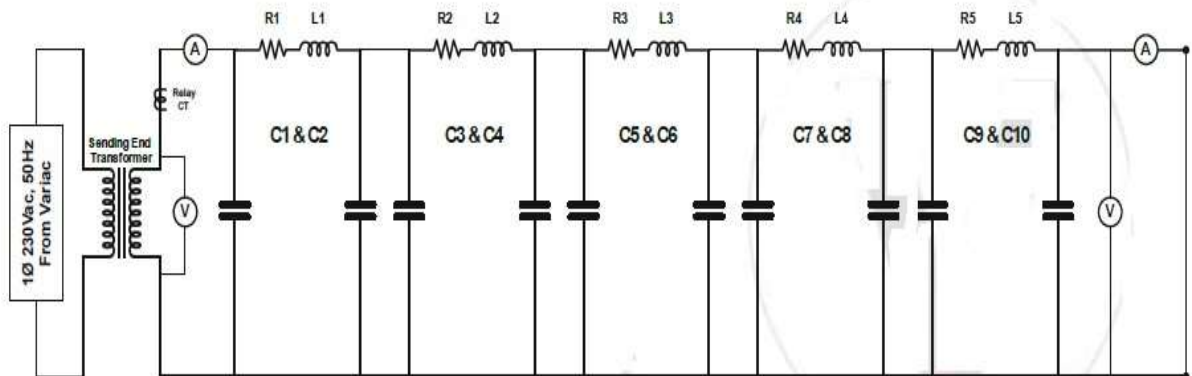

Fig.2. Circuit for short circuit test

PROCEDURE:

1. To find SIL, keep the receiving side open and note down sending end voltage (V_{OC}) and current (I_{SC}).
2. Now, short the receiving end and note down sending end voltage (V_{OC}) and current (I_{SC}). Find impedance in open circuit and short circuit condition.
 - i. $Z_{OC} = \frac{V_{OC}}{I_{OC}}$, $Z_{SC} = \frac{V_{SC}}{I_{SC}}$
3. Find core or natural impedance, Z_0 or $Z_n = \sqrt{(Z_{OC} \cdot Z_{SC})}$
4. $SIL = \frac{V^2}{Z_c}$

TABULAR COLUMN:

Open Circuit Test:

S.NO	Sending End		Receiving End	
	Voltage (V_S)	Current (I_S)	Voltage (V_R)	Current (I_R)
1.				
2.				
3.				

Short Circuit Test:

S.NO	Sending End		Receiving End	
	Voltage (V_S)	Current (I_S)	Voltage (V_R)	Current (I_R)
1.				
2.				
3.				

RESULT:



Bapatla Engineering College:: Bapatla (Autonomous)

TO STUDY CHARACTERISTICS OF MCB & HRC FUSE

AIM:

To study characteristics of MCB & HRC Fuse

APPARATUS:

S.No	Name of the Apparatus	Range	Quantity
1.	Ammeter AC	(0-15 A)	1
2.	1 ph. Dimmer stat	230V,8A	1
3.	Rheostat	(38 Ohm, 8.5 A)	1
4.	Loading Rheostat	--	
5.	Connecting Wires	-	Required
6.	Fuse wire	-	
7.	Stopwatch	-	1

CIRCUIT DIAGRAM:

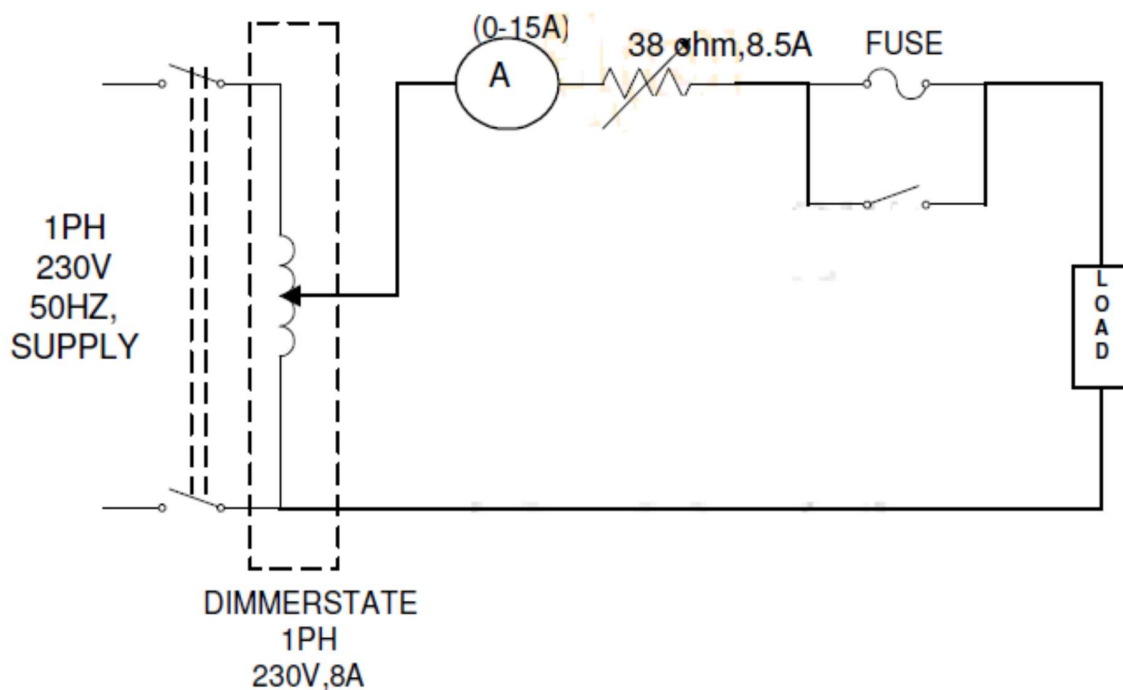



Bapatla Engineering College:: Bapatla (Autonomous)

TABULAR FORM:

S.No.	Current (Amp.)	Time (Sec.)

PROCEDURE:

1. Make the connections as shown in Fig.
2. Switch on the supply and keep the full load in the on position. Adjust the current to certain value with the help of dimmer stat.
3. Stopwatch is stopped when the fuse element is blown which is indicated by decreasing of current in ammeter to zero. Note down the time of stopwatch.
4. Again after changing the fuse element increase the current to certain value and repeat above procedure.

PRECAUTIONS:

- 1) The Circuit connections must be tight.
- 2) Readings are to be taken without parallax error

RESULT:

The characteristics of fuse wire is studied in this experiment and is found to be inverse type, and is plotted on graph paper.



Bapatla Engineering College:: Bapatla (Autonomous)

POLARITY, RATIO AND MAGNETISATION CHARACTERISTICS TEST OF CT AND PT

AIM:

Testing of Polarity, Ratio and magnetisation characteristics of current Transformer and Potential Transformer.

APPARATUS:

Testing of Polarity, Ratio and magnetization characteristics of current Transformer and Potential Transformer.

CIRCUIT DIAGRAM:

Circuit diagram for Polarity test of PT using AC supply:

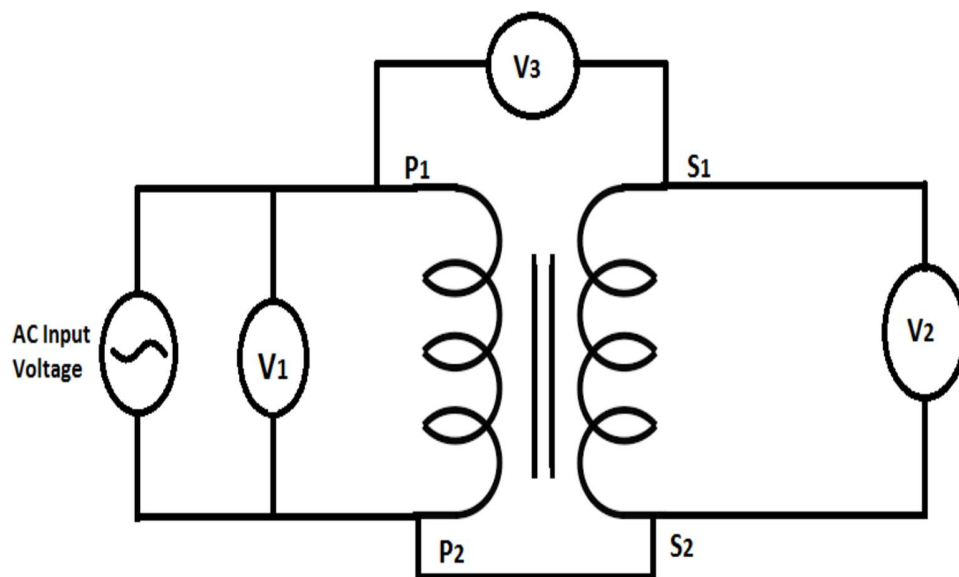



Bapatla Engineering College:: Bapatla (Autonomous)

Circuit diagram of ratio test of PT using AC supply:

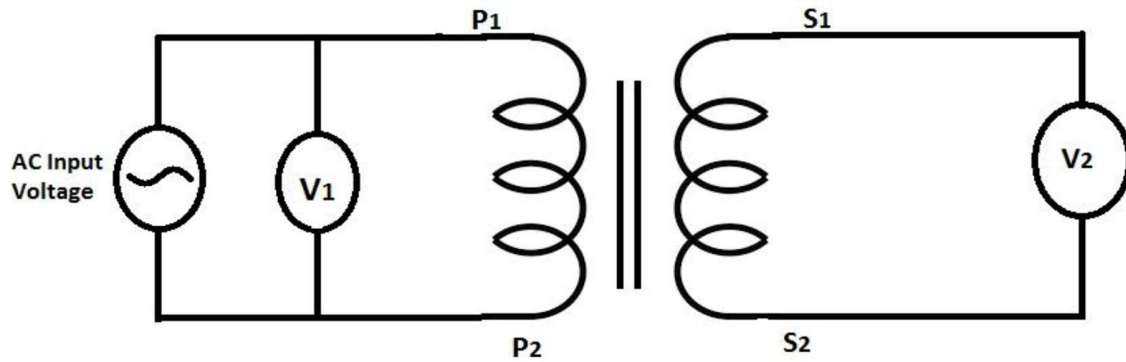

Circuit diagram for Polarity test of CT using DC supply:

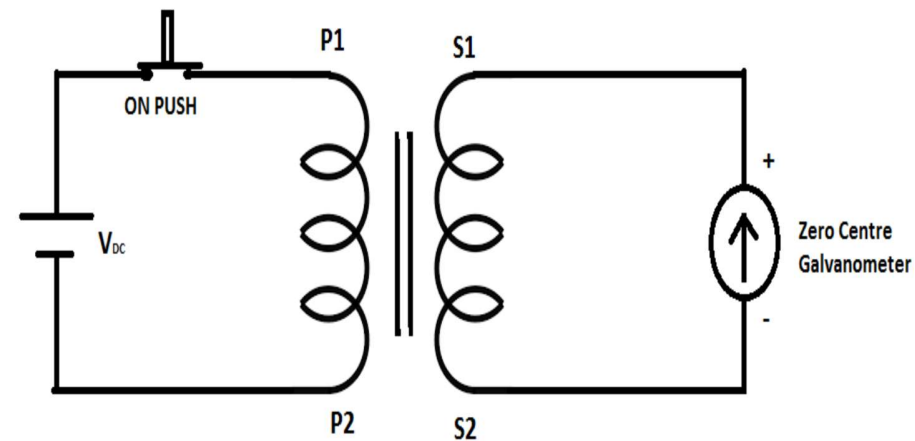

Circuit diagram of ratio test of CT using AC supply:

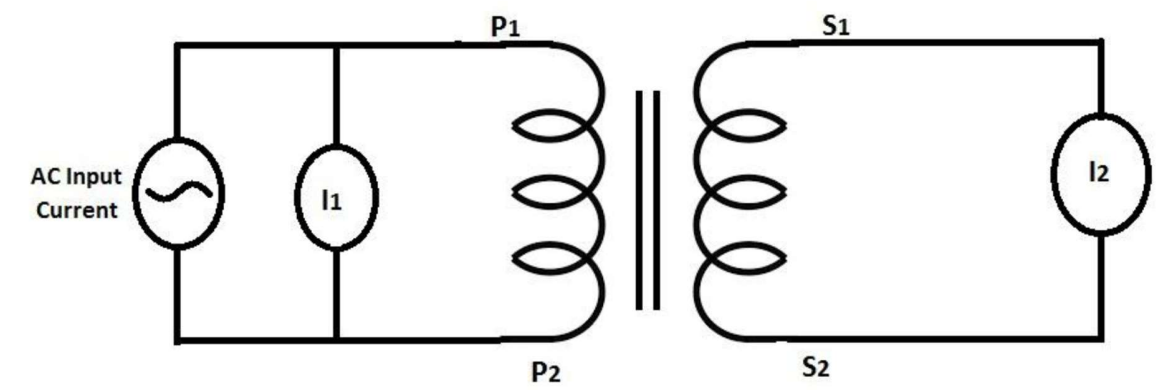



Bapatla Engineering College:: Bapatla (Autonomous)

PROCEDURE:

Polarity test of PT using AC supply:

- 1) Connect the circuit as per circuit diagram and marked the each terminals of primary and secondary winding input voltage at suitable value. Read the input voltage (V_1) and output voltage (V_2).
- 2) If the voltmeter connected between primary and secondary reads the sum of voltages of ($V_1 + V_2$). Then P1 and S1 are opposite polarity.
- 3) If the voltmeter connected between primary and secondary reads the difference of voltages of ($V_1 - V_2$). Then P1 and S1 are same polarity.

Ratio test of PT:

- 1) Connect the circuit as per circuit diagram.
- 2) Connect the PT primary to the output of variable voltage source.
- 3) Increase the input voltage and take input and output voltage reading at least 10 points over its operating range.
- 4) Find out the transformation ratio. Also find error from the given ratio of the transformer.

Polarity test of CT using DC supply:

- 1) Connect the circuit as per circuit diagram and marked the each terminals of primary and secondary winding.
- 2) Be sure the input voltage polarity to the input terminals and polarity of centre galvanometer connection in the output terminals.
- 3) Operate the push button for a fraction of time. Find the direction of deflection of the zero-centre galvanometer.
- 4) If deflection is right hand side that means supply positive terminal and galvanometer positive terminal is same polarity. If deflection is left hand side that means supply positive terminal and galvanometer positive terminal is opposite polarity.
- 5) Repeat the whole experiments after reversing the source.

OBSERVATION AND RESULT:

Polarity test of PT:

Input voltage (V_1)	Output voltage (V_2)	Voltmeter between primary and secondary	Polarity according to marking



Bapatla Engineering College:: Bapatla (Autonomous)

Ratio test of CT:

- 1) Connect the circuit as per circuit diagram.
- 2) Connect the CT primary to the output of variable current source.
- 3) Increase the input current and take input and output current reading at least 10 point over its operating range.
- 4) Find out the transformation ratio. Also find error from the given ratio of the transformer.
- 5) Be sure that at any condition CT secondary will not open during primary energies.



Bapatla Engineering College:: Bapatla (Autonomous)

CHARACTERISTICS OF OVER CURRENT/EARTH FAULT USING NUMERICAL RELAY

AIM:

To study the protection of equipment and system by relays in conjunction with switchgear.

APPARATUS:

S.NO	APPARATUS	Range	Quantity
1.	Timer	-	-
2.	IDMT Relay	-	-
3.	Ammeter	(0-15A)	1
4.	Rheostat	(38 ohm, 8.5 Amp)	1
5.	Connecting wires	-	-

THEORY:

The overcurrent relay works on the induction principle. The moving system consists of an aluminum disc fixed on a vertical shaft and rotating on two jeweled bearings between the poles of an electromagnet and a damping magnet. The winding of the electromagnet is provided with seven taps (generally 0, which are brought on the front panel, and the required tap is selected by a push-in -type plug. The pick-up current setting can thus be varied by the use of such plug multiplier setting. The pick-up current values of earth fault relays are normally quite low.

The operating time of all overcurrent relays tends to become asymptotic to a definite minimum value with increase in the value of current. This is an inherent property of the electromagnetic relays due to saturation of the magnetic circuit. By varying the point of saturation, different characteristics can be obtained and these are

1. Definite time
2. Inverse Definite Minimum Time (IDMT)
3. Very Inverse



Bapatla Engineering College:: Bapatla (Autonomous)

Overcurrent or Earth - fault Relay

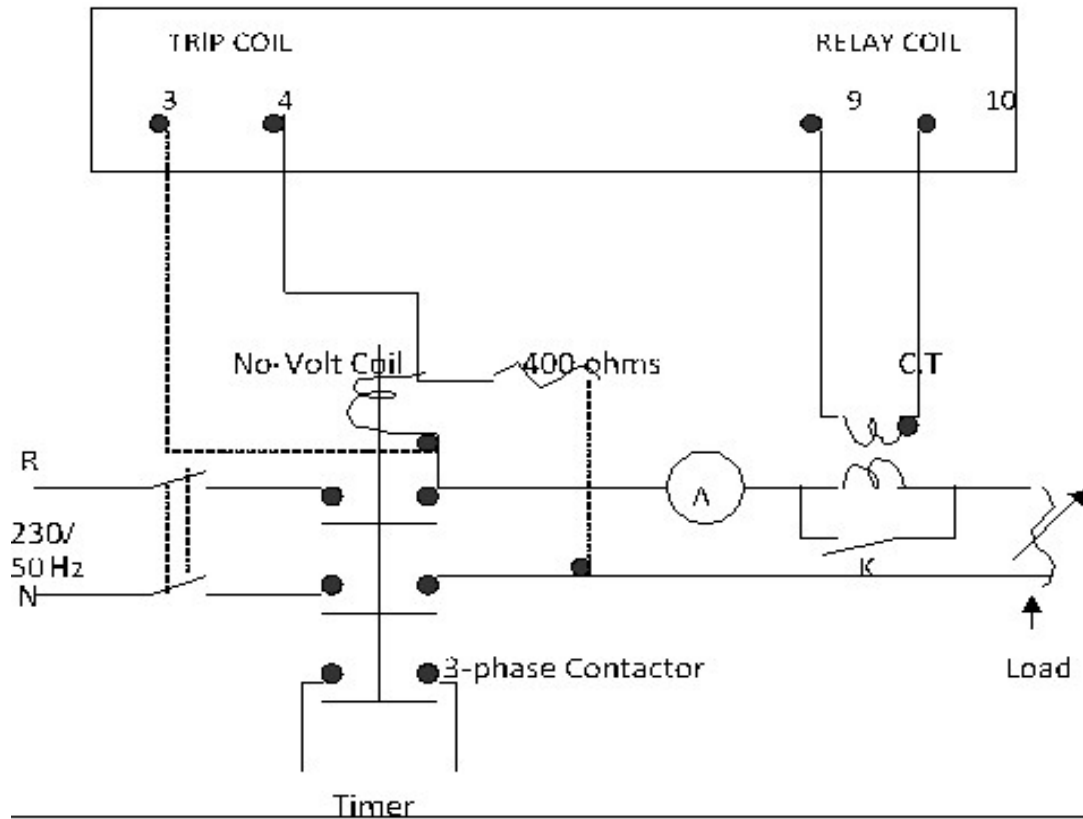

CIRCUIT DIAGRAM:

Over current Relay

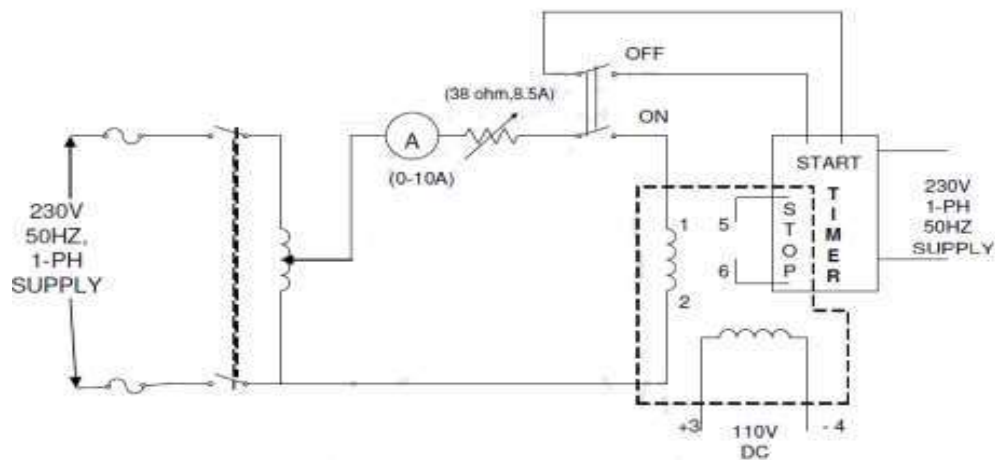



Bapatla Engineering College:: Bapatla (Autonomous)

Earth fault Relay:

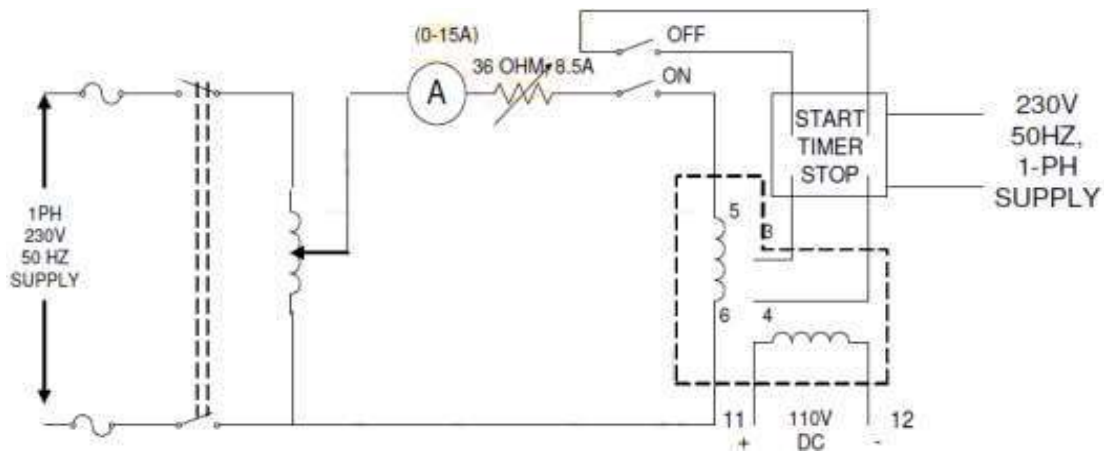

PROCEDURE:

1. Connections are made as per the circuit diagram.
2. Change the TEST/SET knob to the test mode.
3. Switch ON the PC and open the software.
4. Click the connect the button which is installed in software before initializing the relay.
5. Select the Siemen's protection and press OK.
6. Click on the get settings displayed on the screen.
7. Select the current protection in the get settings. Select the phase over current and then select 51:1.
8. Check whether the 'CHAR' is in DTL (Definite Time Logic) mode.
9. Then, select DELAY (DTL) and change timer to 4sec.
10. Select on the update changed settings and click on OK.
11. Now go back to over current relay and press the START button below the relay display.
12. Observe the timer display in the relay panel.
13. Choose the CHAR in the pc and click on the DTL and select the IEC.NI (Normal inverse curve).
14. Choose the time multiplier to 0.2 sec and update changed settings by clicking on OK.
15. Now go back to relay and press the button and observe the timer and ammeter.
16. Reduce the current control knob by rotating in anticlockwise a little bit.
17. Again press the start button below the relay the display, then observe the ammeter and timer displays.
18. Repeat the process by giving more than 1A for different values of current by rotating the current control knob.
19. Change the TEST/SET knob to SET position, press the start button.
20. Now increase the current control knob exactly to 2A and press the STOP button below the relay.
21. Now put in the TEST mode (for selecting the current keep it in the set mode and while running the relay keep it the test mode).



Bapatla Engineering College:: Bapatla (Autonomous)

22. Press the start button (below relay) and observe the time for 2A current. Again keep the knob in SET mode and increase the current to 2A and change the knob to test mode observe the timer.
23. Switch of the MCB change the connections to the Earth fault relay.
24. Switch ON the supply, click on the phase over current relay and select the measured earth fault and choose 51: G1.
25. Check whether the 'CHAR' is in DTL (Definite Time Logic) mode.
26. Then, select DELAY (DTL) and change timer to 4sec.
27. Select on the update changed settings and click on OK.
28. Now go back to over current relay and press the START button below the relay display.
29. Observe the timer display in the relay panel.
30. Switch of the power supply.

TABULAR FORM:

Pick-up current (plug setting multiplier) = ----- Amps

S.No	Current, A	Current(A) times the plug setting multiplier	Operating time in sec. for TMS of				
			0.2	0.4	0.6	0.8	1.0

PRECAUTIONS:

- 1) The Circuit connections must be tight.
- 2) Readings are to be taken without parallax error.

RESULT:



Bapatla Engineering College:: Bapatla (Autonomous)

NUMERICAL DIFFERENTIAL RELAY

AIM:

To determine the operating characteristics of numerical differential relay for protecting 3-Phase Transformer protection.

APPARATUS:

Relay Settings	
Base Power	47.7 MVA
Base Voltage (HV)	230 kV
I (reference) HV	0.125 kA
I (reference) LV	0.125 kA
PT ratio (HV)	220kV/110V
PT ratio (LV)	110kV/110V
CT Ratio (HV)	2000/5
CT Ratio (LV)	1700/5
CT Ratio (HV) Neutral	2000/5
CT Ratio (LV) Neutral	1700/5

Experiment Setup settings	
CTR (HV)	60/5
CTR (LV)	50/5



Bapatla Engineering College:: Bapatla (Autonomous)

CIRCUIT DIAGRAM:

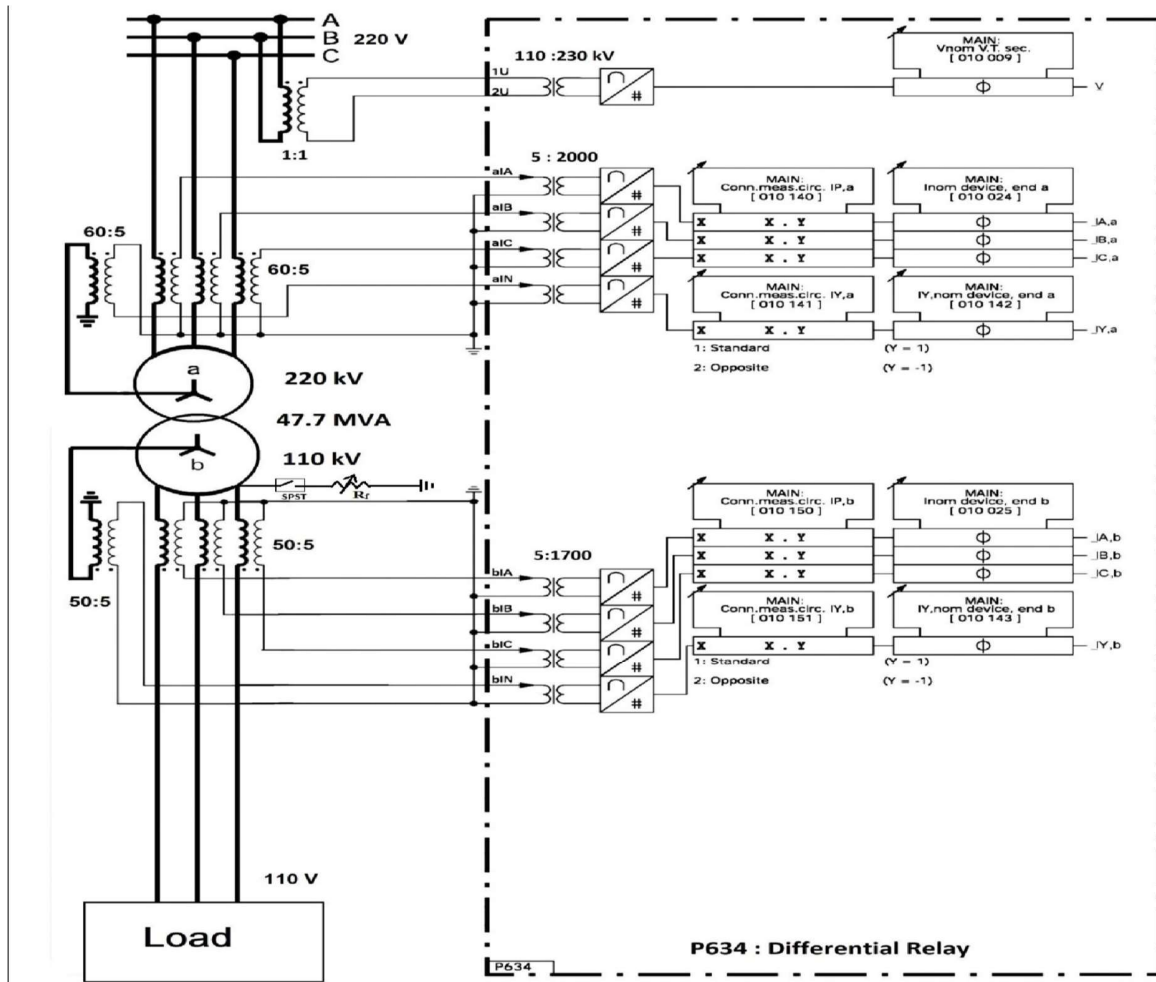

TABULAR FORM:

Table-1:

S. No	Load current(A)	Fault current(A)	Differential current(P.U)	Restraining current(P.U)



Bapatla Engineering College:: Bapatla (Autonomous)

Table-2:

S. No	Load current(A)	Fault current(A)	Differential current (P.U)	Restraining current (P.U)

Tripping characteristics of the relay

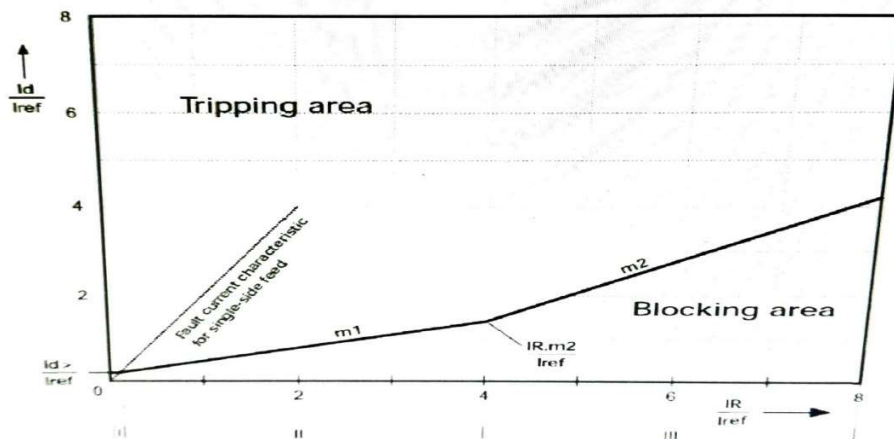

PROCEDURE:

1. Set $m_1 = 0.2$ and $m_2 = 0.6$ (slopes of the characteristic).
2. Create a fault of high resistance in any one phase in the LV winding of the transformer bank.
3. Gradually decrease the resistance of the fault.
4. Note down the load current and fault current in the system, along with the restraining and differential
5. current in the device when it generates trip command.
6. Do the experiment for a wide range of load currents i.e. restraining currents (in device).
7. Set $m_1 = 0.4$ and $m_2 = 0.8$ and repeat the experiment.

PRECAUTIONS:

- 1) The Circuit connections must be tight.
- 2) Readings are to be taken without parallax error

RESULT:

1. Plot differential current vs. restraining current and fault current vs. load current.
2. Find the slopes and knee points corresponding to different regions from the plot.



Bapatla Engineering College:: Bapatla (Autonomous)

STUDY OF SOLAR/WIND TURBINE GENERATOR POWER PLANT

This is a solar-wind hybrid system of capacity 3KW, out of which 2.5KW is the solar panel and 500W of wind turbine.

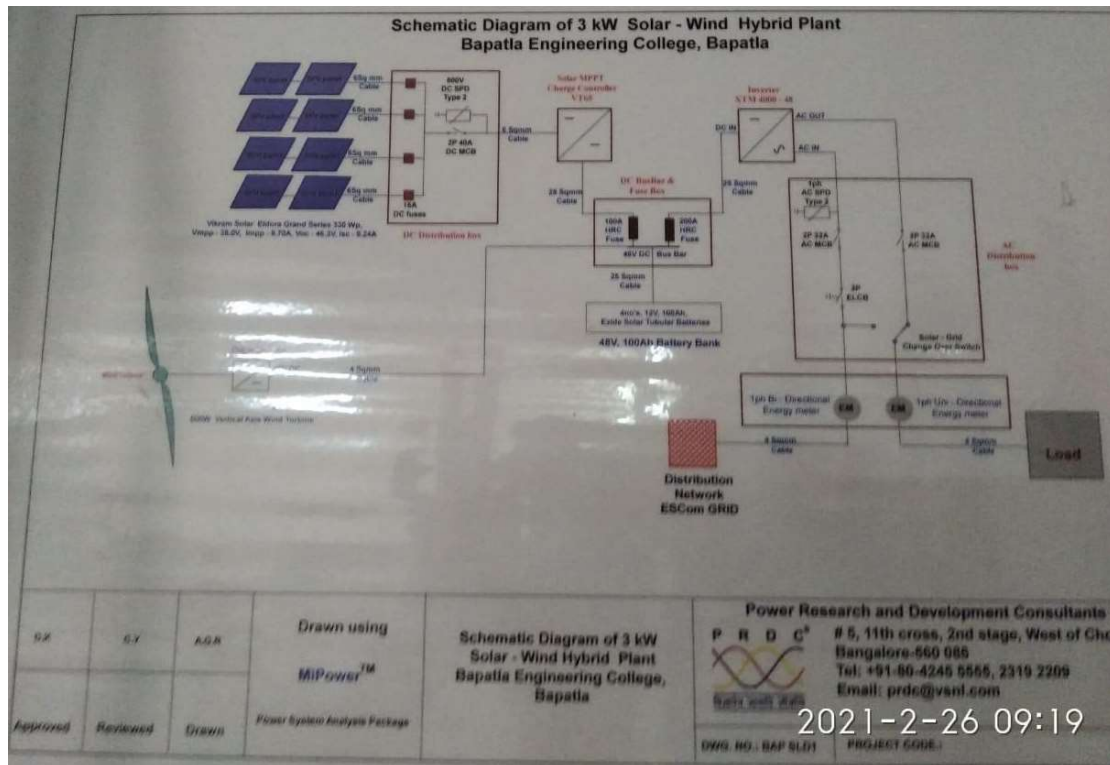

SINGLE LINE DIAGRAM EXPLANATION:

There are 8 panels each panel has 30watt capacity solar poly crystal solar panels each panel has 2.6KW cumulatively 3KW switch on. The output of the solar panels is given to the DCDB (DC Distribution Box). In DCDB it will have solar fuses dedicated for the two panels.

The two panels will be in DCDB and they will have 4 strings, all strings will be connected to the DC bus bar so it will be treated as a parallel so after 4 string will be treated as single string, so it follows DCDB solar 4 in 1 out. This is physical configuration made for solar/wind hybrid power system.

DCDB will have 4 strings and 1 string output that 1 string will be given to the charge controller. Here we use DC 65/48v. the output of the charge controller will give to battery fuse box so there it will be connected to the battery system through the DC bus bar.



Bapatla Engineering College:: Bapatla (Autonomous)

PARTS:

BATTERYS: 4 batteries are used here each of the capacity 12v 10c is are connected in series and the output of the battery bank is connected to the fuse box which consist of the DC Bus Bar and the 100A HRC fuse. And the fuse box output to the inverter XTM 4000 of the 48v 4KW two side inverter.



CHARGE CONTROLLER: this is the 65v 4KW charge controller MBPD charge controller.

- First MCB is the leakage current breaker. This trip the system during the time of the leakage currents.
- The second MCB is the surge protection device. This protects the system from the surges.
- 3rd MCB is the input protection for the system.
-
- 4th MCB (black colour) is the change over switch. If any thing goes wrong in the system, the switch will totally bypass the system connected load directly to the input system.
- 5th MCB is used for the circuit breaker for the load.



REMOTE MONOTERING SYSTEM: it records all the parameters of the system. Like the:

- AC input system
- AC output system
- Battery status
- And so on

This information is sent to the cloud and the users id and the password will be given to the user. By using this the data of the system can be accessed from anywhere in the world by just logging into the system cloud and this is done by using the LAN connected to the RMS.



INVERTER: the front panel of the inverter is explained here with some light indication.



Bapatla Engineering College:: Bapatla (Autonomous)

AC ON – inverter is on the load is connected to the inverter.

AC IN – the inverter is taking the AC supply as the input.

CHARGING – battery is charging.

ON – the inverter is ON.

OFF – the inverter is OFF.

The inverter has pipes connected to it in the bottom.

Starting from the left side:

- 1st input to the inverter
- 2nd output from the inverter
- 3rd communication to the RMS.
- 4th body grounding
- 5th system grounding



MBPD CHARGE CONTROLLER: this charge controller indicates the weather the battery is charging or not by help of LEDs

The green colour led indicates the charging current of the battery and the battery status.

The orange colour light indicates the 3 things:

- Charging
- Not charging
- Switch off.

The charge controller has some wires running out, in the right side the red and blue are the input from the i,e 4 in 1 out string and the left side is the output of the charge controller positive and negative here both are black in colour. This will be connected to the fuse box through the 100A HRC fuse.



BATTERY MAINTANACE: the battery is equipped with the indicator on the top and that shows the battery condition if the indicators floaters are below the red line the we need to put some distilled water to bring back the battery to it working condition.

SOLAR PANEL: 8 panels are used and 4 connected in pairs as a 4 string. They are arranged at an angle of 50 degree towards the south.



Bapatla Engineering College:: Bapatla (Autonomous)

VERTICAL AXIS WIND TURBINE: the shaft of the turbine is connected to the permanent magnet generator which produces DC power supply.

LIGHTNING ARRESTER: as these solar panels are placed on the roof of the building there is a chance of lightning strike. So, to protect the system from lightning, lightning arresters are used.