



**Bapatla Engineering College::Bapatla
(Autonomous)**

Bapatla Engineering College

(Autonomous)

BAPATLA



**Department of Electrical & Electronics Engineering
Basic Electrical and Electronics Engineering Lab (18EEL01) MANUAL
R18 REGULATIONS**



Bapatla Engineering College:: Bapatla

(Autonomous under Acharya Nagarjuna University)

(Sponsored by Bapatla Education Society)

BAPATLA-522102, Guntur District, A.P.

www.becbapatla.ac.in



Bapatla Engineering College::Bapatla (Autonomous)

Vision of the Department

The Department of Electrical & Electronics Engineering will provide programs of the highest quality to produce globally competent technocrats who can address challenges of the millennium to achieve sustainable socio-economic development.

Mission of the Department

- M1. To provide quality teaching blended with practical skills.
- M2. To prepare the students ethically strong and technologically competent in the field of Electrical and Electronics Engineering.
- M3. To motivate the faculty and students in the direction of research and focus to fulfill social needs.

Program Educational Objectives (PEOs)

- PEO1.** To have a strong foundation in the principles of Basic Sciences, Mathematics and Engineering to solve real world problems encountered in modern electrical engineering and pursue higher studies/placement/research.
- PEO2.** To have an integration of knowledge of various courses to design an innovative and cost effective product in the broader interests of the organization & society.
- PEO3.** To have an ability to lead and work in their profession with multidisciplinary approach, cooperative attitude, effective communication and interpersonal skills by participating in team oriented and open ended activities.
- PEO4.** To have an ability ability to enhance career development, adapt to changing professional and societal needs by engaging in lifelong learning.

Program Outcomes:

Engineering graduates will be able to:

- PO1. Engineering knowledge:** Apply the knowledge of mathematics, science, engineering fundamentals and an engineering specialization to the solution of Electronics and Instrumentation Engineering. problems.
- PO2. Problem analysis:** Identify, formulate, research literature and analyze complex engineering problems reaching, substantiated conclusions using first principles of mathematics, natural sciences and engineering sciences.



Bapatla Engineering College::Bapatla (Autonomous)

PO3. Design/development of solutions: Design solutions for problems in the field of Electronics and Instrumentation Engineering and design system components or processes that meet the specified needs with appropriate consideration for public health and safety and the cultural, societal and environmental considerations.

PO4. Conduct investigations of complex problems: Use research-based knowledge and research methods including design of experiments, analysis and interpretation of data and synthesis of the information to provide valid conclusions.

PO5. Modern tool usage: Create, select, and apply appropriate techniques, resources and modern engineering and IT tools including prediction and modeling to complex engineering activities with an understanding of the limitations.

PO6. The Engineer and Society: Apply reasoning informed by the contextual knowledge to assess societal, health, safety, legal and cultural issues and the consequent responsibilities relevant to the professional engineering practice.

PO7. Environment and Sustainability: Understand the impact of the Electronics and Instrumentation Engineering solutions in societal and environmental contexts, and demonstrate the need for sustainable development.

PO8. Ethics: Apply ethical principles and commit to professional ethics and responsibilities and norms of the engineering practice.

PO9. Individual and Team work: Function effectively as an individual and as a member or leader in diverse teams and in multidisciplinary settings.

PO10. Communication: Communicate effectively on Electronics and Instrumentation Engineering activities with the engineering community and with the society at large, such as being able to comprehend and write effective reports and design documentation, make effective presentations and receive clear instructions.

PO11. Project management and Finance: Demonstrate knowledge and understanding of the engineering and management principles and apply these to one's own work as a member and leader in a team to manage projects in a multidisciplinary environment.



Bapatla Engineering College::Bapatla (Autonomous)

PO12. Life-long Learning: Recognize the need for and have the preparation and ability to engage in independent and life-long learning in the broadest context of technological change.

Program Specific Outcomes (PSO's)

PSO1: The Electrical and Electronics Engineering graduates are capable of applying the Knowledge of mathematics and sciences in modern power industry.

PSO2: Analyse and design efficient systems to generate, transmit, distribute and utilize electrical energy to meet social needs using power electronic systems.

PSO3: Electrical Engineers are capable to apply principles of management and economics for providing better services to the society with the technical advancements in renewable and sustainable energy integration.



Bapatla Engineering College::Bapatla (Autonomous)

Basic Electrical and Electronics Engineering Lab (18EEL01)

I B. Tech-I/II Semester (Code: 18EEL01)

Lectures	0	Tutorials	0	Practical	3	Credits	1
Continuous Internal Evaluation			50	Semester End Examination (3 hours)		5	

Prerequisites: None.

Course Objective: To make the students

1: Able To understand basic Laws in circuits, analysis of simple DC circuits, Theorems and its applications, fundamentals of AC circuits & its analysis and concepts of three phase balanced circuits

2:To learn basic properties of magnetic materials and its applications.

3:To understand working principle, construction, applications and performance of DC machines, AC machines.

4:To learn basic concepts, working principal, characteristics and applications of semiconductor diode and transistor family.

5:To gain knowledge about the static converters and regulators.

6. To learn basic concepts of power transistors and operational amplifiers closer to practical applications.

Course Outcomes: Students will be able to

CO1: Validate the basic network theorems such as KCL, KVL, superposition, Thevenin's and Norton's theorems.

CO2: Measure the parameters of choke coil.

CO3: Figure out the parameters, regulation, and efficiency of single-phase transformer.

CO4: Discriminate between the characteristics of PN junction diode, Zener diode and Transistor.



Bapatla Engineering College::Bapatla (Autonomous)

Basic Electrical and Electronics Engineering Lab

I B. Tech-I/II Semester (Code: 18EEL01)

Lectures	0	Tutorials	0	Practical	3	Credits	1
Continuous Internal Evaluation			50	Semester End Examination (3 hours)		5	

LIST OF EXPERIIMENTS:

1. Verification of KCL and KVL
2. Verification of Superposition theorem
3. Verification of Thevenin's theorem
4. Verification of Norton's theorem
5. Parameters of choke coil
6. Measurement of low and medium resistance using volt ampere method
7. OC & SC test of single phase transformer
8. Load test on single phase transformer
9. V-I characteristics of PN junction Diode
10. V-I characteristics of Zener Diode
11. Characteristics of CE Configuration
12. Transfer and Drain Characteristics of JFET 43
13. Calculation of Ripple factor using Half wave rectifier
14. Calculation of Ripple factor using Full wave rectifier
15. Non linear wave shaping – clippers/clampers.

NOTE: Minimum 10experiments should be conducted.



Bapatla Engineering College::Bapatla (Autonomous)

Verification of KCL and KVL

AIM:

To Verify KCL and KVL for the Given Circuit.

APPARATUS:

S.NO	APPARATUS	TYPE	QUANTITY	RANGE
1.	Ammeter	MC	3	(0-5)A
2.	Voltmeter	MC	1	(0-30)V
		MC	3	(0-15)V
3.	Rheostat	WW	1	8Ω/10A
		WW	1	12Ω/5A
		WW	1	20Ω/5A
4	Regulated power supply(RPS)	Digital	1	(0-30)V/5A
5.	Connecting wires	Multi strands 1sq.mm	Required number

THEORY:

KCL: This law is applied at any node of an electric network. This law states that the algebraic sum of currents meeting at a junction or a node in a circuit is zero. KCL can be expressed mathematically as

$$\sum_{j=1}^n I_j = 0$$

where n is the number of branches meeting at a node and I_j represents the current in the j^{th} branch as has been shown in Fig.

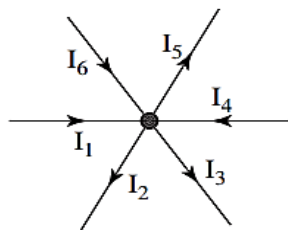

or

$$I_1 + I_6 + I_4 - I_5 - I_3 - I_2 = 0$$

$$I_1 + I_6 + I_4 = I_5 + I_3 + I_2$$

The sum of current flowing towards a junction or a node is equal to the sum of currents flowing out of the junction. The current entering the junction has been taken as positive while the currents leaving the junction have been taken as negative. That is to say there is no accumulation of current in a junction.



Bapatla Engineering College::Bapatla (Autonomous)

KVL states that at any instant of time the algebraic sum of voltages in a closed loop is zero. In applying KVL in a loop or a mesh a proper sign must be assigned to the voltage drop in a branch and the source of voltage present in a mesh. For this, a positive sign may be assigned to the rise in voltage and a negative sign may be assigned to the fall or drop in voltage. KVL can be expressed mathematically as

$$\sum_{j=1}^n V_j = 0$$

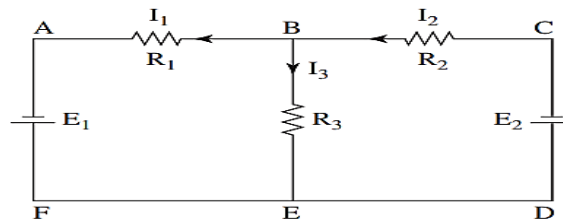

Now, let us apply KVL in mesh ABEFA and mesh CBEDC, respectively. For the mesh ABEFA, starting from point A, the sum of voltage drops and voltage rise are equated to zero as

$$+I_1 R_1 - I_3 R_3 - E_1 = 0$$

$$I_1 R_1 - (I_2 - I_1) R_3 - E_1 = 0$$

Circuit Diagram For KVL:

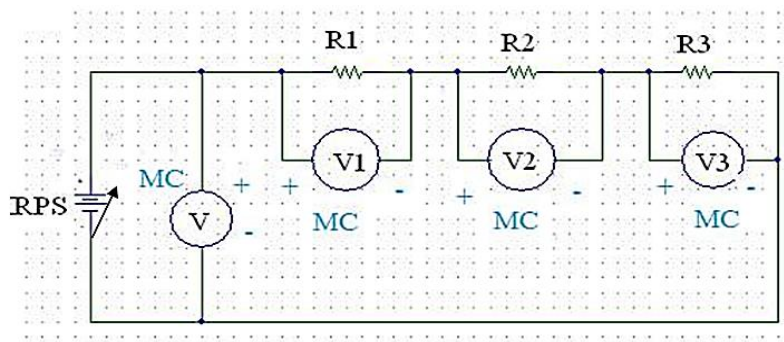

Circuit Diagram For KCL:

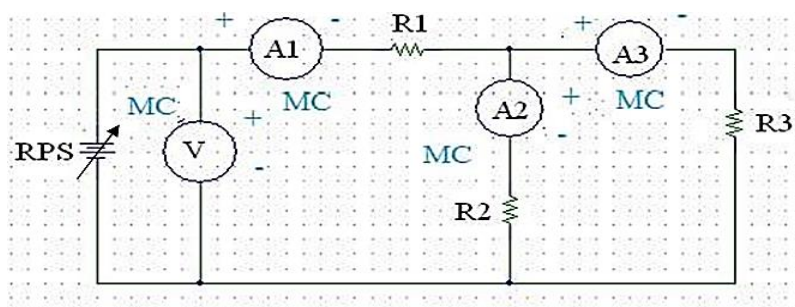



Bapatla Engineering College::Bapatla (Autonomous)

PROCEDURE:

KVL:

1. Make the connections according to the circuit diagram.
2. Switch on the power supply.
3. By using RPS, vary the voltage in steps 5 volts up to 25 volts and note down the readings of the voltmeters.

KCL:

1. Make the connections according to the circuit diagram.
2. Switch on the power supply.
3. By using RPS, vary the voltage in steps of 5 volts up to 25 volts and in each case measure the readings of the ammeters.

TABULARCOLUMN: For KVL

S.No	APPLIED VOLTAGE, V_s (Volts)	V_1 (Volts)	V_2 (Volts)	V_3 (Volts)	$V_s=V_1+V_2+V_3$

TABULARCOLUMN: For KCL

S.No	APPLIED VOLTAGE, V_s (Volts)	I_1 (Amp)	I_2 (Amp)	I_3 (Amp)	$I_1=I_2+I_3$ (Amp)

PRECAUTIONS:

All connections should be tight and correct.
Before switching on the RPS, voltage knob should be kept at minimum position and current knob should be kept at maximum position.
Reading should be taken without parallax error.

RESULT: Kirchhoff's laws are verified.



Bapatla Engineering College::Bapatla (Autonomous)

VERIFICATION OF SUPER POSITION THEOREM

AIM: To Verify Superposition theorem for the given circuit.

APPARATUS:

S.No	Name Of The Equipment	Range	Type	Quantity
1	Voltmeters	(0-30)V	MC	3NO
2	Ammeter	(0-3)A	MC	3NO
3	RPS	0-30V	Digital	1NO
4	Resistors	8 Ω /10A	WW	1NO
		12 Ω /5A	WW	1NO
		20 Ω /5A	WW	1NO
5	Connecting Wires	-	-	As required

THEORY

The superposition theorem states that in a linear network containing more than one source, the current flowing in any branch is the algebraic sum of currents that would have been produced by each source taken separately, with all the other sources replaced by their respective internal resistances. In case the internal resistance of a source is not provided, the voltage sources will be short circuited and current sources will be open circuited.

If network contains two or more sources, then principle of superposition theorem is used to simplify network calculations.

- 1) First by using mesh analysis find the current through AB say as "I".

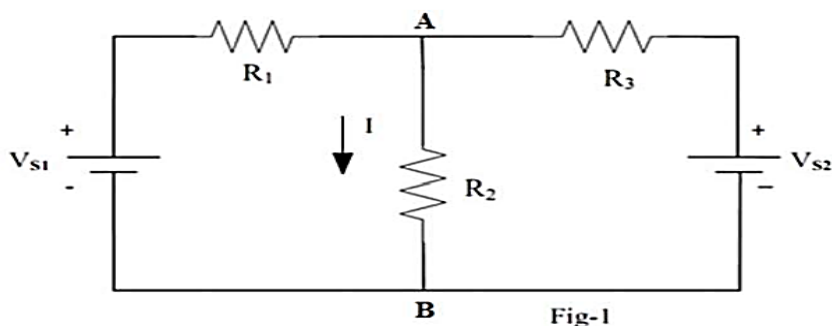



Bapatla Engineering College::Bapatla (Autonomous)

- 2) According to superposition theorem first V_{s1} acting only then V_{s2} is replaced by short circuited. (Internal resistance of voltage source is zero) then find the current through “AB” say it as “ I_1 ”.

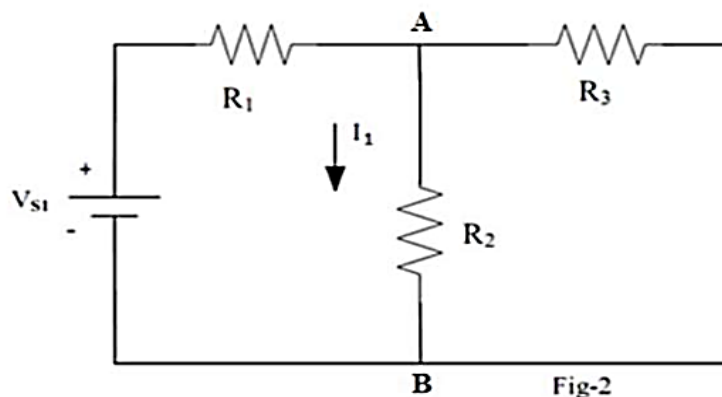

- 3) Similarly V_{s2} is acting alone; V_{s1} is short circuited then find the current through “AB” say it as “ I_2 ”.

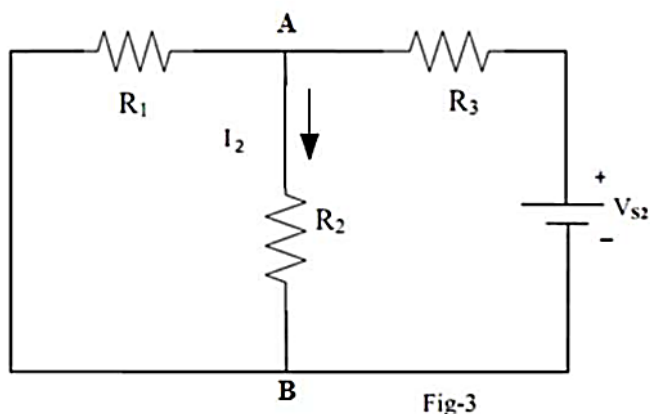

- 4) Total current in the resistor connected across “AB” is

$$I = I_1 + I_2 \text{ (if currents are in same direction).}$$

$$I = I_1 - I_2 \text{ (if currents are in opposite direction).}$$

Verification:

The current calculated by step 1 is equal to current calculated by step 4 hence superposition theorem is verified.



Bapatla Engineering College::Bapatla (Autonomous)

CIRCUITDIAGRAM-1:

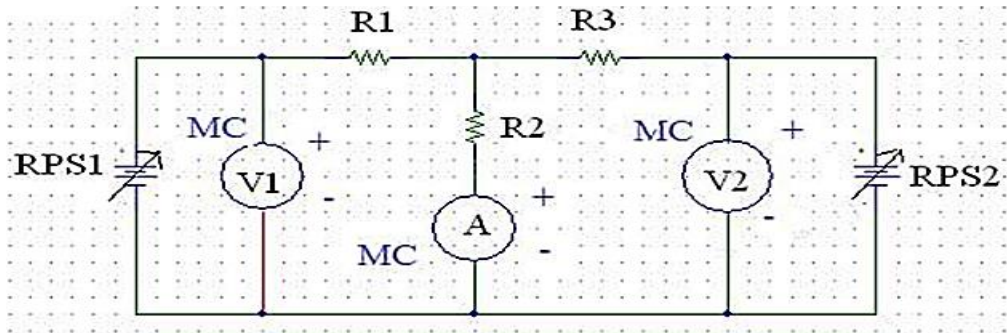

CIRCUITDIAGRAM-2:

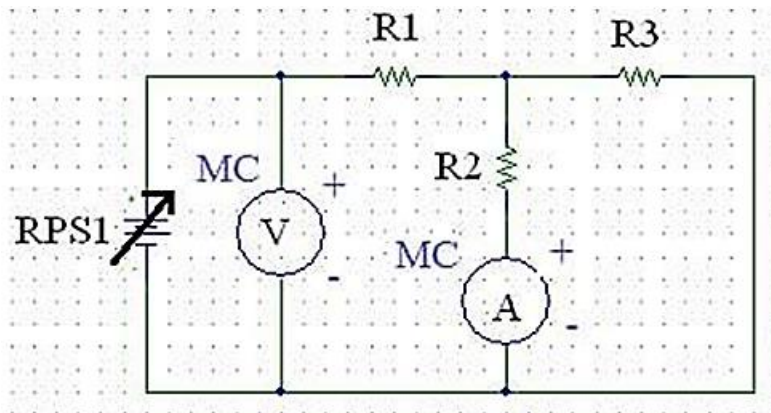

CIRCUITDIAGRAM-3:

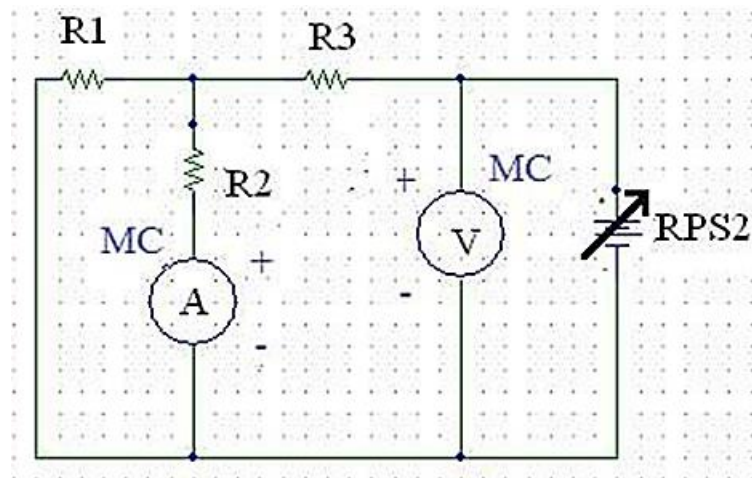



Bapatla Engineering College::Bapatla (Autonomous)

PROCEDURE:

1. Connections are made as per the circuit diagram 1.
2. Switch on the power supply and vary the RPS 1 and 2 in steps of 5V up to 20V and note down the corresponding ammeter reading.
3. Connections are made as per the circuit diagram 2. Vary RPS1 in steps of 5V up to 20v and take the corresponding ammeter reading.
4. Connections are made as per the circuit diagram 3. Vary RPS2 in steps of 5V up to 20v and take the corresponding ammeter reading.

TABULARCOLUMN-1: When Both Sources are connected

S.No	Applied voltage, V_1 (V)	Applied voltage, V_2 (V)	Current, I_1 (A)	$I_1=I_1'+I_1''$
1				
2				
3				
4				
5				

TABULARCOLUMN-2: When only First source is connected

S.No	Applied voltage, V_1 (V)	Current, I_1' (A)
1		
2		
3		
4		
5		

TABULARCOLUMN-3:When only Second source is connected

S.No	Applied voltage, V_2 (V)	Current, I_1'' (A)
1		
2		
3		
4		
5		



Bapatla Engineering College::Bapatla (Autonomous)

PRECAUTIONS:

1. Connections should be tight.
2. The readings are noted without parallax error.
3. Before switching on the RPS, the current knob should be kept at maximum and voltage knob kept at minimum position.

RESULT: Superposition Theorem is verified.



Bapatla Engineering College::Bapatla (Autonomous)

Verification of Thevenin's theorem

AIM: To Verify Thevenin's Theorem for the Given Circuit.

APPARATUS:

S.No	Apparatus	Type	Quantity	Range
1.	Ammeter	MC	1	(0-30)A
2.	Voltmeter	MC	2	(0-30)V
3.	RPS	DIGITAL	1	(0-30)V/5A
4.	Rheostat	WW	1	8Ω/10A 12Ω/5A 20Ω/5A
5.	Connecting wires	Multi strands 1sq.mm	Required number

Theory:

Any two terminals of an electrical network consisting of active and passive elements (i.e., voltage sources and resistors) can be replaced by an equivalent voltage source and an equivalent series resistance. The voltage source is the open-circuit voltage between the terminals caused by the active network. The series resistance is the equivalent resistance of the whole circuit across the terminals looking to the circuit from the two terminals with all the sources of EMF short circuited.

Any network having terminals A and B can be replaced by a single source of e.m.f V_{TH} in series with a source resistance R_{TH} . The Thevenin's equivalent resistance is the resistance measured across points A and B "looking back" into the circuit. It is important to first replace all voltage- and current-sources with their internal resistances. For an ideal voltage source, this means replace the voltage source with a short circuit. For an ideal current source, this means replace the



Bapatla Engineering College::Bapatla (Autonomous)

current source with an open circuit. Resistance can then be terminals using the formulae for series and parallel circuits.

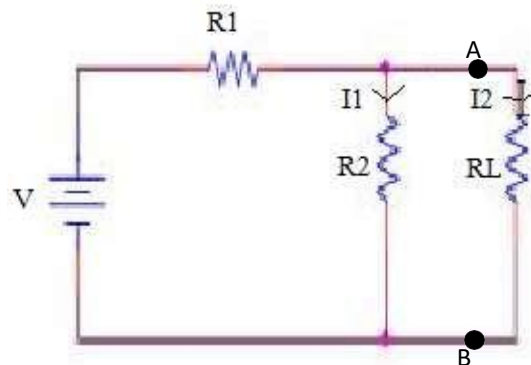

In short the steps are,

1. Find the Thevenin's source voltage by removing the load resistor from original circuit and calculating voltage across the open connection points where the load resistor used to be.

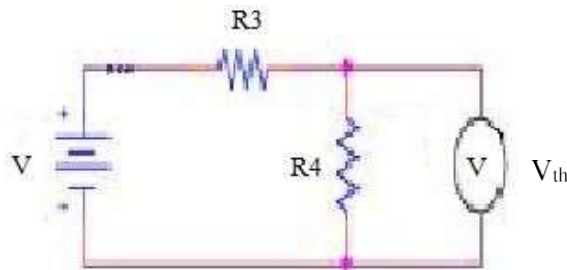

Find the Thevenin's resistance by removing all power sources in the original circuit (voltage sources shorted and current sources open) and calculating total resistance between the open connection points.

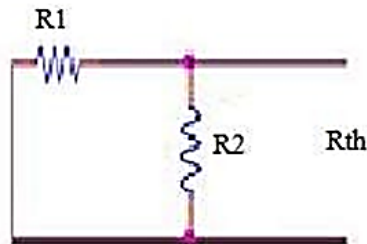

3. Draw the Thevenin's equivalent circuit, with the Thevenin's voltage source in series with the Thevenin's resistance. The load resistor re-attaches between the two open points of the equivalent circuit.



Bapatla Engineering College::Bapatla (Autonomous)

CIRCUIT DIAGRAMS:

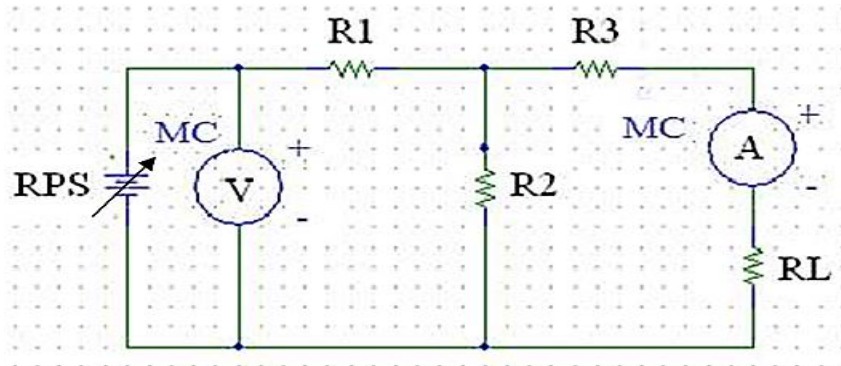

Figure(1)

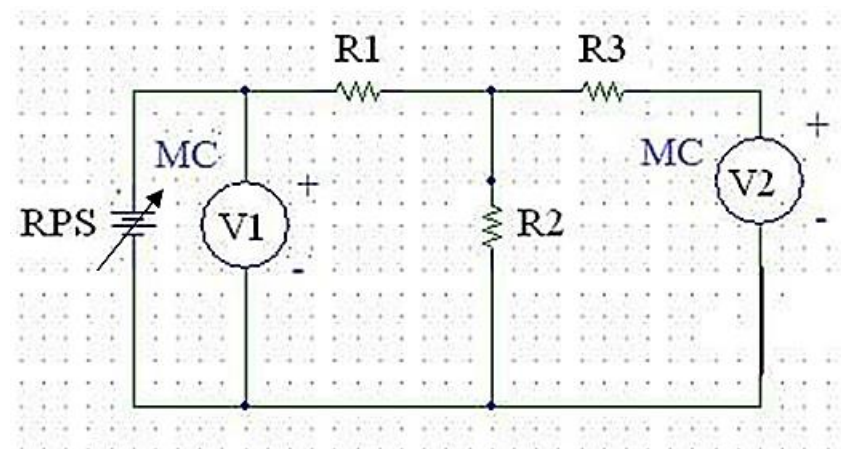

Figure(2)

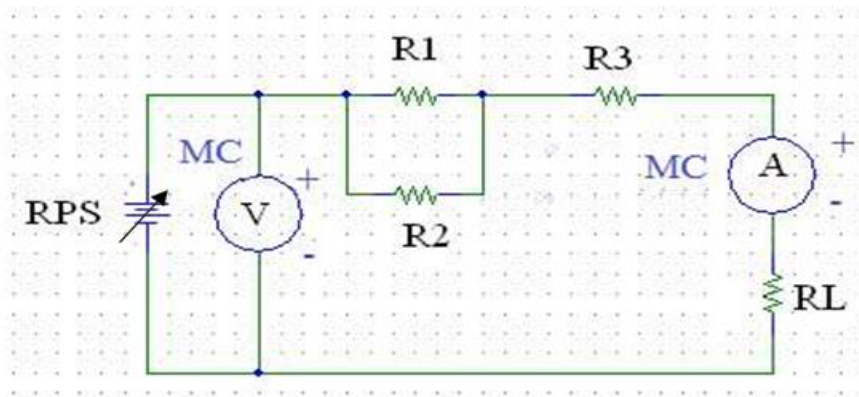

Figure(3)



Bapatla Engineering College::Bapatla (Autonomous)

PROCEDURE:

1. Connect the circuit as per fig (1).
2. Switch on power supply, Vary the RPS in steps of 5V up to 20V and note down the ammeter and voltmeter readings.
3. Disconnect the circuit and connect as per the fig (2).
4. Adjust the output voltage of the regulated power supply as in first circuit.
5. Note down the voltage across the load terminals AB (Voltmeter reading) that gives V_{th} .
6. Disconnect the circuit and connect as per the fig (3).
7. Apply the open circuit voltage same as obtained from circuit 2 and note down the load current which must be same as that the current obtained from circuit 1.

TABULAR FORM: For Circuit-1

S.NO	Applied voltage , V_1 (V)	Practical	Theoretical
		Load current, I_L (A)	Load current, I_L (A)
1			
2			
3			
4			

Tabular form for Circuit-2

S.NO	Applied voltage , V_2 (V)	Practical	Theoretical
		Open circuit voltage, V_{oc} (V)	Open circuit voltage, V_{oc} (V)
1			
2			
3			
4			



Bapatla Engineering College::Bapatla (Autonomous)

Tabular form for Circuit-3

S.NO	Open circuit voltage, $V_{oc}(V)$	Practical	Theoretical
		Load current, $I_L(A)$	Load current, $I_L(A)$
1			
2			
3			
4			

PRECAUTIONS:

1. Connections should be tight.
2. The readings are noted without parallax error.
3. Before switching on the RPS, the current knob should be kept at maximum and voltage knob kept at minimum position.

RESULT: Thevenin's Theorem is verified.



Bapatla Engineering College::Bapatla (Autonomous)

Verification of Norton's theorem

AIM: To Verify Norton's Theorem for the given circuit.

APPARATUS:

S.No	Apparatus	Type	Quantity	Range
1.	Ammeter	MC	1	(0-30)A
2.	Voltmeter	MC	2	(0-30)V
3.	RPS	DIGITAL	1	(0-30)V/5A
4.	Rheostat	WW	1	8 Ω /10A 12 Ω /5A 20 Ω /5A
5.	Connecting wires	Multi strands 1sq.mm	Required number

Theory:

Any two terminal networks consisting of voltage sources and resistances can be converted into a constant current source and a parallel resistance. The magnitude of the constant current is equal to the current which will flow if the two terminals are short circuited and the parallel resistance is the equivalent resistance of the whole network viewed from the open-circuited terminals after all the voltage and current sources are replaced by their internal resistances.

CIRCUIT DIAGRAM:1

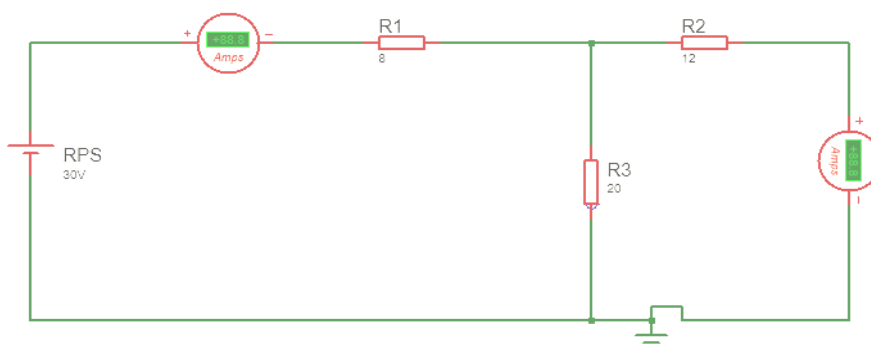



Bapatla Engineering College::Bapatla (Autonomous)

CIRCUIT DIAGRAM:2

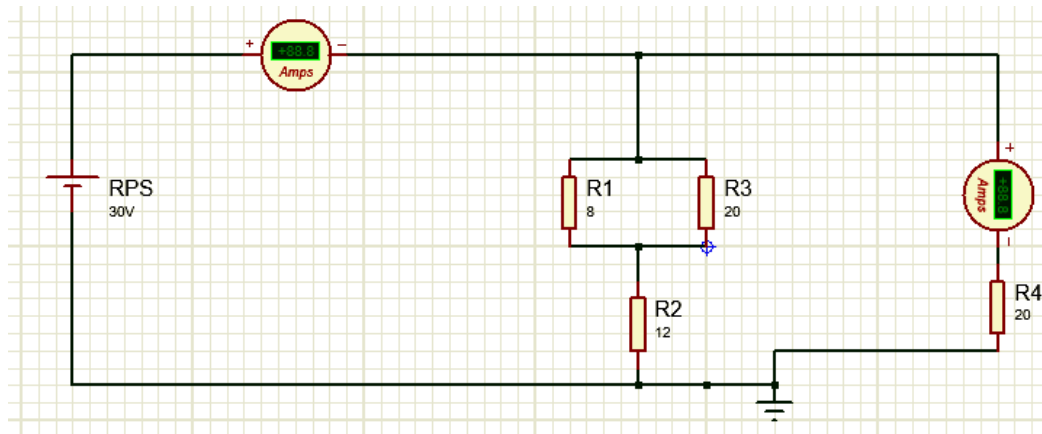

CIRCUIT DIAGRAM:3

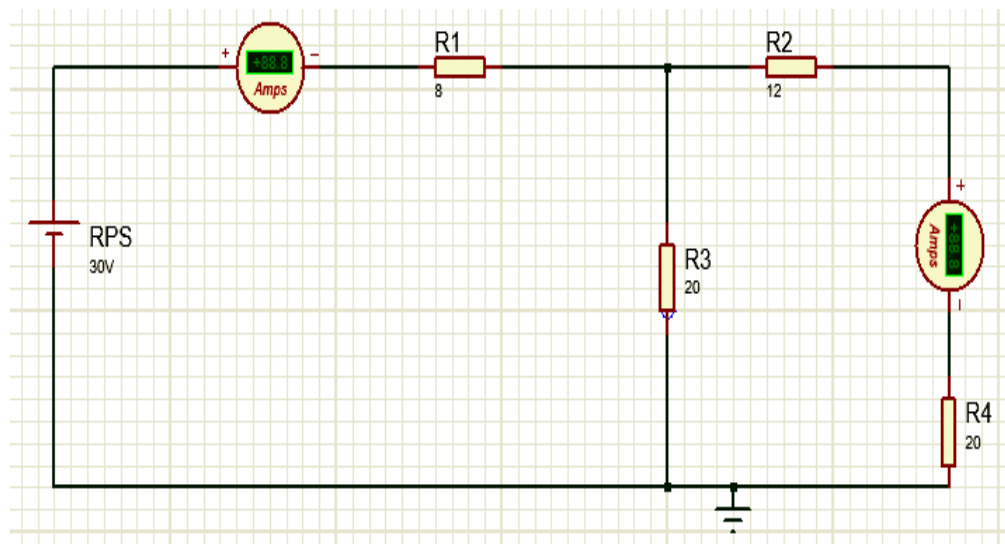

PROCEDURE:

1. Connect the Circuit as per the circuit diagram1
2. Apply the current by varying RPS in steps of 0.5A in Ammeter A1.
3. Note down the readings of Ammeter A2 in each step which is the load current II

Circuit-2

1. Connect the Circuit as per the circuit diagram2
2. Now apply supply current same as in the table-1 and note down the corresponding short circuit current readings in Ammeter A2
3. Tabulate the readings in Table-2.

Circuit-3



Bapatla Engineering College::Bapatla (Autonomous)

1. Connect the Circuit as per the circuit diagram³
2. Apply the short circuit current readings at source side
3. Note down the readings of Load current.

TABULAR FORM:1

S.No	Applied voltage(V)	Supply current(A)	Load current I_l (A)	Theoretical Load current

TABULAR FORM:2

S.No	Applied voltage(V)	Supply current(A)	Short Circuit current I_{sc} (A)	Theoretical Short Circuit current I_{sc} (A)

TABULAR FORM:3

S.No	Short Circuit current I_{sc} (A)	Load Current I_l (A)	Theoretical Load Current I_l (A)

PRECAUTIONS:

1. Connections should be tight.
2. The readings are noted without parallax error.
3. Before switching on the RPS, the current knob should be kept at maximum and voltage knob kept at minimum position.

RESULTS: Norton's Theorem is verified.



Bapatla Engineering College::Bapatla (Autonomous)

Parameters of choke coil

AIM: To find the parameters (R_{ac} , L , Power factor (PF) & Quality factor (QF)) of a given choke coil.

APPARATUS:

S.NO	Name of the Equipment	Type	Range	Quantity
1	Ammeter	MI	(0-5)A	1
		MC	(0-1.5)A	1
2	Voltmeter	MI	(0-150)V	1
		MC		1
4	1-phase auto T/F	IC	230V/(0-270)V	1

Theory:

The term Choke itself represents smother, (lock and the term Coil Itself indicates a reactor consisting of a spiral of insulated wire that introduces inductance into a circuit.

Definition: An inductor which provides high impedance to alternating current with little resistance to direct current. Choke coils are often used in radio circuits and to smooth the output of a rectifying circuit.

A choke- is the common name given to an inductor that is used as a power supply filter element. They are typically gapped iron core units, similar in appearance to a small transformer, but with only two leads exiting the housing. The current in an inductor cannot change instantaneously/ that is, inductors tend to resist any change in current flow. This property makes them good for use as filter elements, since they tend to -smooth out- the ripples in the rectified voltage waveform. Typically an inductor is designed to have high reactance to a particular frequency when used in signal carrying circuit. They are inductances that isolate AC frequency currents from certain areas of radio circuit. Choke coil depends upon the property of self inductance for their operation. They are used to (lock alternating current while passing direct current.



Bapatla Engineering College::Bapatla (Autonomous)

Circuit diagram to find RDC:

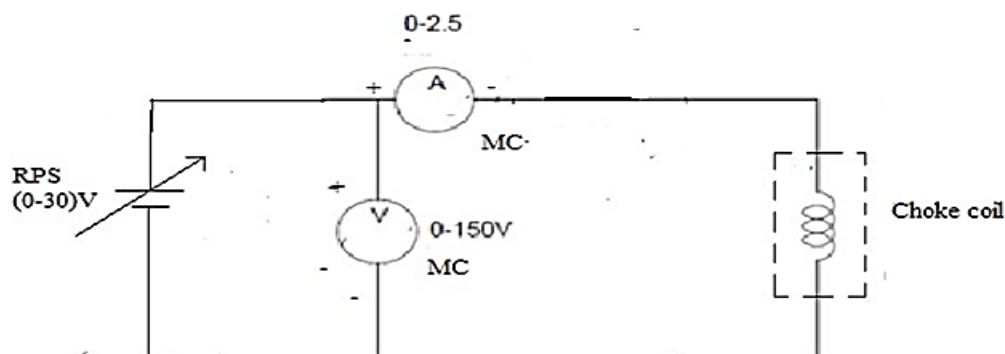

Circuit diagram to find Z:

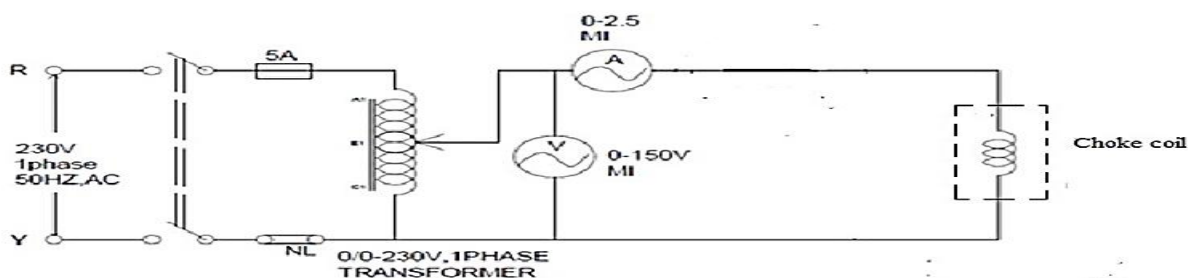

Procedure to Find R_{dc}:

1. Connections are made as per circuit diagram.
2. Vary the RPS in steps of 5V and note down the corresponding Ammeter (I_{dc}) and voltmeter (V_{dc}) readings.
3. Calculate the $R_{dc} = V_{dc} / I_{dc}$ in each step.
4. Average the readings and find R_{dc} .

Procedure to find Z:

1. Connections are made as per circuit diagram.
2. Vary the Auto T/F in steps of 20V by varying from minimum to maximum position and note the corresponding Ammeter (I_{ac}) and voltmeter (V_{ac}).
3. Calculate the $Z = V_{ac} / I_{ac}$ in each step.
4. Average the readings and find Z.



Bapatla Engineering College::Bapatla (Autonomous)

Calculations:

$$R_{dc} = V_{dc} / I_{dc}$$

$$R_{ac} = 1.11 * R_{dc}$$

$$Z = V_{ac} / I_{ac}$$

$$L = \sqrt{Z^2 - R_{ac}^2} / (2\pi f), f = 50\text{Hz}$$

$$PF = \cos\phi = R_{ac} / Z$$

$$QF = R_{ac} / X_L$$

Precautions:

1. Connections should be tight.
2. Readings should be taken without parallax error.
3. Autotransformers should be varied from minimum position to maximum position and brought to minimum position after the completion of experiment.

Result: Parameters of choke coil are determined.



Bapatla Engineering College::Bapatla (Autonomous)

OC&SC test of single phase transformer

AIM:

To find out the losses and the draw the characteristics of a 1-phase transformer by conducting OC & SC test.

APPARATUS:

S.NO	Name of the Equipment	Type	Range	Quantity
1	Ammeter	MI	(0-5)A	1
		MI	(0-1.5)A	1
2	Voltmeter	MI	(0-150)V	1
3	Wattmeter	EDW	250V/2.5A, UPF	1
		EDW	75V/5A, UPF	1
4	1-phase auto T/F	IC	230V/(0-270)V	1

THEORY:

Open-circuit Test or No-load Test In this test the transformer primary winding is supplied with its rated voltage keeping the secondary winding unconnected to the load, i.e., with no-load on the secondary. Normally, the supply is given to the low-voltage winding. The high-voltage winding is kept open. Three measuring instruments, viz a wattmeter, a voltmeter, and an ammeter are connected to the low voltage side as shown in Fig The equivalent circuit of the transformer has also been shown under no-load condition in Fig The wattmeter connected on the L.V. side will record the input power, W_o to the transformer. The supply voltage is measured by the voltmeter and the no-load line current is measured by the ammeter reading, I_o . The input power, W_o is

$$W_o = V_1 I_o \cos \phi_0 \text{ W}$$
$$\cos \phi_0 = \frac{W_o}{V_1 I_o}$$
$$I_c = I_o \cos \phi_0$$
$$I_m = I_o \sin \phi_0$$

Since on no-load the output is zero, the input power is utilized in supplying the no-load losses. At no-load there will be no current in the secondary winding and hence no copper loss will take place in that winding. The primary winding current on no-load is small. There will be losses in the iron core which will have two components, viz hysteresis loss and eddy current loss. Thus,



Bapatla Engineering College::Bapatla (Autonomous)

the wattmeter reading on no-load can be approximately equated to core loss only. From the no-load test data we, will be able to know the core loss of the transformer, no-load current, the no-load power factor, the magnetizing reactance, and the resistance R_c corresponding to core loss. Note that core loss calculated on no-load will be the same as on full-load or at any other load. That is why core loss of a transformer is considered to be a constant loss as it does not depend on the load currents. Core loss depends on the supply voltage and its frequency.

Short-circuit Test In this test, the secondary winding is short circuited with a wire and a reduced voltage is applied across the primary winding. One voltmeter, one wattmeter, and an ammeter are connected in the primary circuit for the measurement of the applied voltage under the short-circuit condition, V_{sc} , the power consumed, W_{sc} and the current, I_{sc} , respectively. It may be noted that for convenience, the low-voltage winding is usually short circuited which forms the secondary winding. The instruments are connected in the high-voltage winding circuit where the rated current is comparatively lower than the low-voltage side, as has been shown in Fig. This is done by using an auto transformer. Under the short-circuit condition only a very small percentage of rated voltage, say about five per cent, has to be applied to the primary winding to circulate the full-load current through the windings. Current in the primary winding (H.V. winding) will also be lower than that of the low-voltage winding. Thus, by conducting the short-circuit test from the high voltage winding side with the low-voltage winding short-circuited, we can have an accurate measurement.

Circuit diagram for OC test:

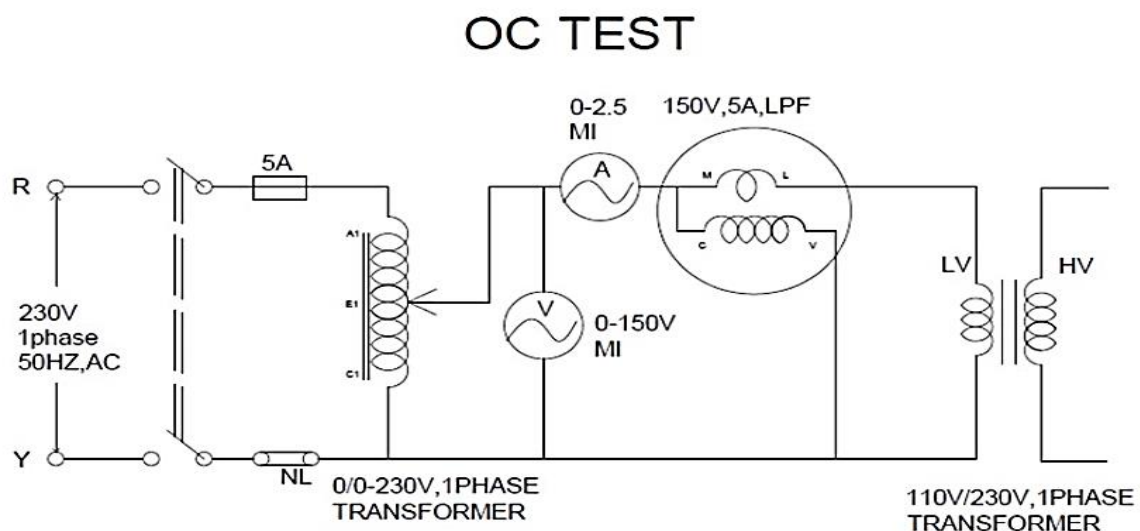



Bapatla Engineering College::Bapatla (Autonomous)

Circuit diagram for SC test:

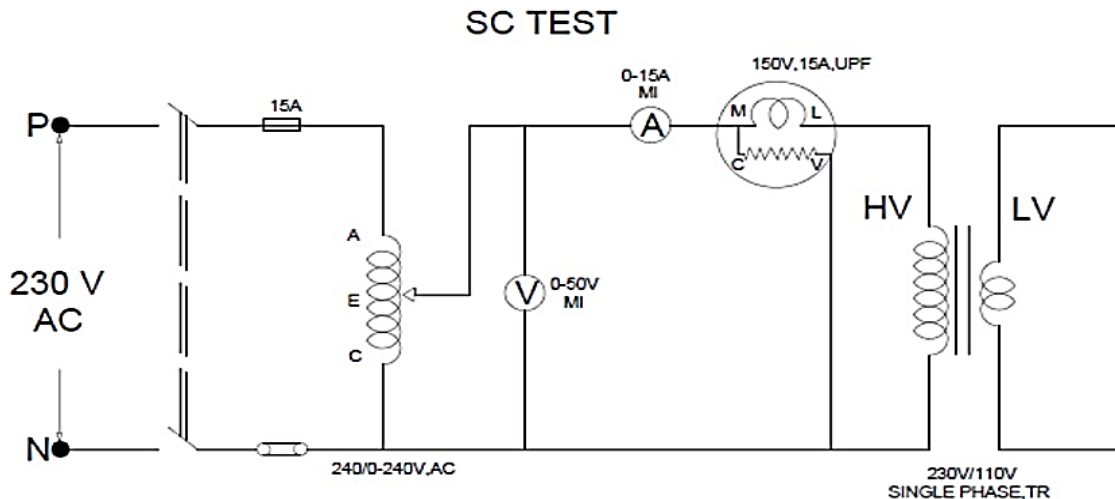

Procedure:

a) For OC test:

- 1) Connections are made as per circuit diagram.
- 2) Switch ON the supply using the DPST switch.
- 3) Apply rated voltage to one of the transformer.
- 4) Note down the readings of Voltmeter, ammeter and wattmeter.
- 5) Bring the Auto T/F to its initial position before switching OFF the supply.

b) For SC test:

- 1) Connections are made as per the circuit diagram.
- 2) Vary the auto T/F till we get rated current (4.3A) on the SC side of the T/F.
- 3) Note down the readings of Voltmeter, ammeter and wattmeter.
- 4) Bring the Auto T/F to its initial position before switching OFF the supply.



Bapatla Engineering College::Bapatla (Autonomous)

Tabularform for OC test:

S.NO	V _{oc} (Volts)	I _{oc} (Amps)	W _{oc} (watts)

Tabular form for SC test:

S.NO	V _{sc} (Volts)	I _{sc} (Amps)	W _{sc} (watts)

Efficiency = output/input = $V_{oc}I_{sc} \cos\phi / (V_{oc}I_{sc} \cos\phi + W_{oc} + W_{sc})$ for different values of $\cos\phi = 0.2, 0.4, 0.6 \dots$

Regulation = $(I_{sc}R \cos\phi + X I_{sc} \sin\phi) / V_{oc}$ for different values of $\cos\phi = 0.2, 0.4, 0.6 \dots$

Where $Z = V_{sc} / I_{sc}$, $R = W_{sc} / I_{sc}^2$

$$X = \sqrt{Z^2 - R^2}$$

Modelgraphs:

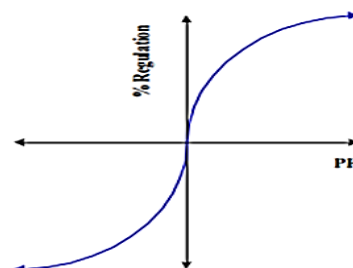
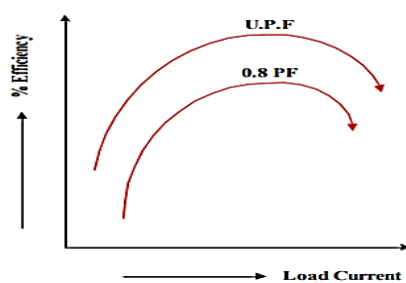



Bapatla Engineering College::Bapatla (Autonomous)

Precautions:

- 1) Connections should be tight.
- 2) Readings should be taken without parallax error.
- 3) Autotransformers in SC and OC tests should be at the initial and final positions before and after the test respectively.

Result: The characteristics of a 1-phase transformer by conducting OC & SC test are drawn.



Bapatla Engineering College::Bapatla (Autonomous)

Load test on single phase transformer

AIM: To perform Load test on 1- ϕ Transformer and draw its performance characteristics.

APPARATUS:

S.NO	Name of the Equipment	Type	Range	Quantity
1	Ammeter	MI	(0-3)A	1
2	Voltmeter	MI	(0-300)V	1
3	Wattmeter	EDW	300V/5A,UPF	1
4	1- ϕ AutoT/F	IC	230V/(0-270)V, 5A	1
5	1- ϕ T/F	IC	230V/230V, 1KVA	1
6	1- ϕ resistive load	--	230V/5A	1

THEORY:

The load test is performed on a single phase transformer, to find out its efficiency and regulation. In this method, a resistive load is connected to the transformer and it's loaded up to the rated current. This is direct loading method and can be applied to transformers with a rating less than 5kVA. When some electrical load is connected across the secondary terminals, power will be supplied to the load from the primary supply via the magnetic circuit. A current of I_2 will flow in the secondary circuit. The voltage available across the load, V_2 will be somewhat less than E_2 . When the transformer is loaded, the secondary current I_2 will create flux in the core in the opposite direction to that of the original core flux ϕ which was produced on no-load. Thus, the resultant flux will get reduced momentarily. This will reduce the induced EMF E_1 and E_2 . As E_1 is reduced, the difference between V_1 and E_1 will increase and due to this more current of amount I_1' will flow from the supply mains through the primary winding. This current will produce an opposing flux to that produced by I_2 such that $I_2 N_2 = I_1' N_1$. Then, the two fluxes will balance each other, and hence the original flux ϕ will remain unchanged in the core. Irrespective of the magnitude of the load current, the net core flux remains practically constant at all load conditions.



Bapatla Engineering College::Bapatla (Autonomous)

Circuit diagram:

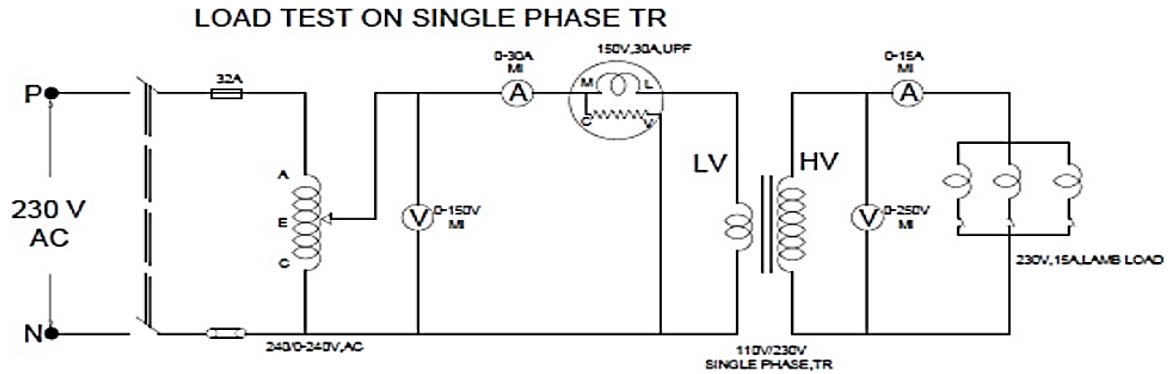

Procedure:

1. Connections are made as per circuit diagram.
2. Switch ON the supply and apply rated voltage across the primary using the 1- ϕ T/F.
3. At this instant note down the readings of Voltmeter, ammeter and wattmeter.
4. Then apply the load in stepwise up to the rated current of secondary and note down the readings of all the meters, then calculate efficiency and also regulation.

Tabular form:

S.NO	I/P voltage(V)	O/P power(W)	Load voltage(V)	Load current(I)	% η	%R



Bapatla Engineering College::Bapatla (Autonomous)

Model graph:

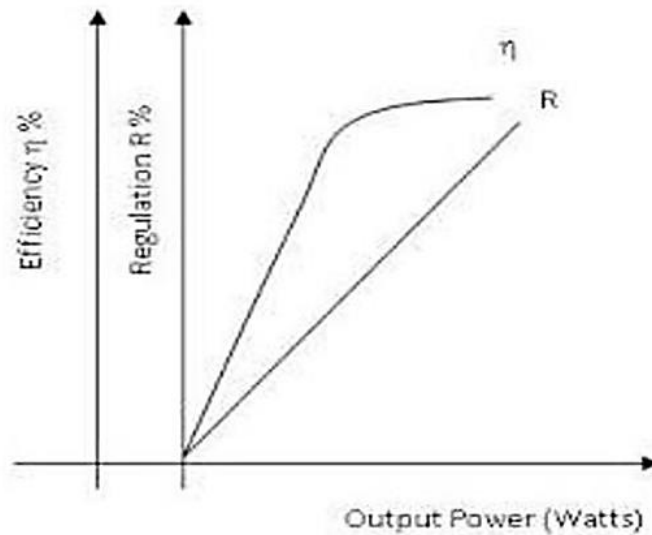

Precautions:

- 1) Connections should be tight.
- 2) Readings should be taken without parallax error.
- 3) Autotransformer should be at the initial position before starting the test.

RESULT: Performance characteristics of 1- ϕ Transformer are drawn by conducting load test on it.



Bapatla Engineering College::Bapatla (Autonomous)

V-I Characteristics of PN Junction diode

AIM: To find out the V-I characteristics of silicon and germanium diodes in Forward and Reverse bias configurations.

APPARATUS:

P-N Diodes
Regulated Power supply (0-30v)
Resistor 1K
Ammeters (0-200mA,0-200 μ A), Voltmeter(0-20V) Bread board and Connecting wires.

Theory:

A semiconductor diode is simply a p-n junction which offers very low resistance when forward biased and very high resistance when reverse biased. Diodes are available in different current ratings. Low-current-rated diodes are used in switching circuits as the diode works like a switch allowing current to flow in one direction. A p-n junction with connecting leads on both sides form a p-n junction diode as shown in Fig. The p-side is connected to the positive terminal for forward bias and is called anode. The n-side is connected to the negative terminal for forward bias and is called cathode. A very high forward current or a very high reverse voltage can destroy a diode. That is why the manufacturer, data sheet is to be consulted to note the maximum permissible forward current and maximum permissible reverse voltage. High-current power diodes are available these days which allow large forward current and considerable amount of reverse voltage.

When a p-n junction diode is connected to a source of supply in such a way that it is forward biased, the relationship between the voltage applied and current flowing will give us a forward V-I characteristic. The connection diagram for finding the V-I characteristic has been shown in Fig. 11.9. When the applied voltage is gradually increased, at a small value of forward voltage the forward current is negligibly small. At a voltage near 0.3 V, the current suddenly increases. This voltage at which the forward current starts increasing is called the cut-in voltage of the diode. The voltage drop across the diode while it is conducting remains almost constant. For the germanium semiconductor diode, the forward voltage drop is 0.3 V and for the silicon diode, the forward voltage drop is 0.7 V. For determining the reverse characteristic, the supply connection has to be reversed. Under the reverse-biased condition, the junction resistance is very high and ideally no current should flow. But due to minority charge carriers, a negligibly small current of the order of microamperes will flow. This current is also called leakage current of the diode. It gets saturated to its initial value of a few microamperes or even less than that. Increase of



Bapatla Engineering College::Bapatla (Autonomous)

negative biasing, i.e., increase of negative voltage across the diode does not increase this reverse current. However, if the reverse voltage is increased to a large value, at one stage, the p-n junction will break down with a sudden rise in reverse current. The reverse voltage at which the diode breaks down and a large reverse current starts flowing is called the breakdown voltage. At this reverse breakdown voltage, current continues to increase.

CIRCUIT DIAGRAM: Forward Bias Condition

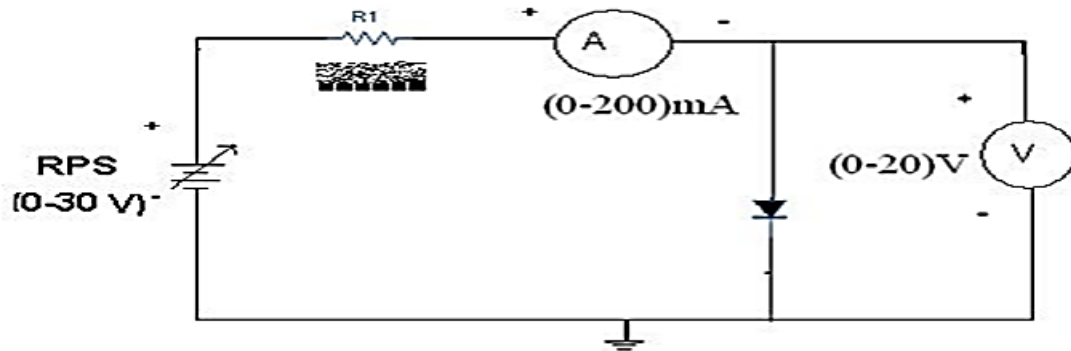

CIRCUIT DIAGRAM : Reverse Bias Condition

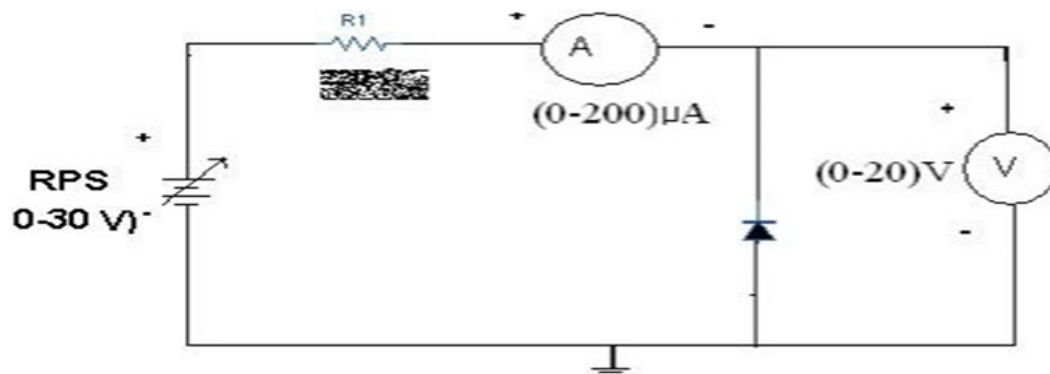

Tabular Form: For Forward Bias

S.No.	Applied Voltage(V)	Voltage Across Diode(V)	Diode Current(mA)



Bapatla Engineering College::Bapatla (Autonomous)

Tabular Form: For Reverse Bias

S.No.	Applied Voltage(V)	Voltage Across Diode(V)	Diode Current(μA)

V-I Characteristics of p-n junction diode

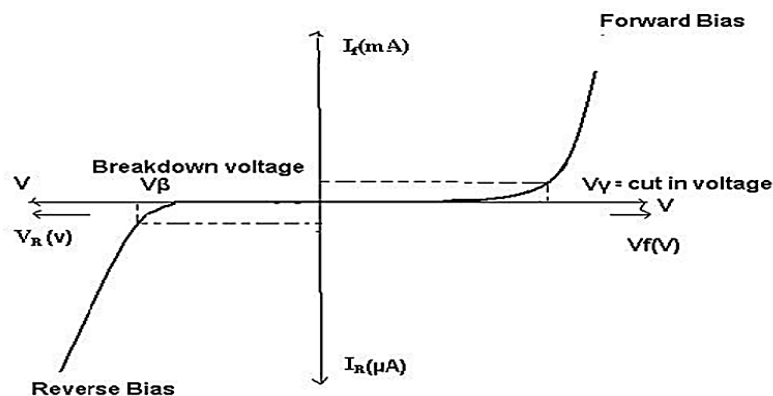

PROCEDURE:

FORWARD BIAS:-

1. Connections are made as per the circuit diagram.
2. For forward bias, the RPS +ve is connected to the anode of the silicon diode and RPS – ve is connected to the cathode of the diode.
3. Switch on the power supply and increases the input voltage (supply voltage) in steps.
4. Note down the corresponding current flowing through the diode and voltage across the diode for each and every step of the input voltage
5. The readings of voltage and current are tabulated and a graph is plotted between voltage and current.
6. Repeat the above procedure for Germanium diode also and tabulate the results.



Bapatla Engineering College::Bapatla (Autonomous)

REVERSEBIAS:-

1. Connections are made as per the circuit diagram
2. For reverse bias, the RPS+ve Is connected to the cathode of the silicon diode and RPS -ve is connected to the anode of the diode.
3. Switch on the power supply and increase the input voltage (supply voltage) insteps.
4. Notedownthecorrespondingcurrentflowingthroughthediodevoltageacrossthe diode for each and every step of the input voltage.
5. The readings of voltage and current are tabulated and graph is plotted between voltage and current.
- 7.Repeat the above procedure for the given Germanium diode also and tabulate the results obtained.

PRECAUTIONS:

1. All the connections should be correct.
2. ParallaxerrorsshouldbeavoidedwhiletakingthereadingsfromtheAnalogmeters.

RESULT: The V-I Characteristics of P-n junction diode are drawn.



Bapatla Engineering College::Bapatla (Autonomous)

V-I Characteristics of Zener diode

AIM: To observe and draw the static characteristics of a zener diode

APPARATUS:

Zenerdiode
Regulated Power Supply (0-30v)
Voltmeter (0-20v)
Ammeter (0-00mA)
Resistors (1Kohm)
Bread Board and Connecting wires.

Theory:

We have known that when a diode is reverse biased, only a minutely small current called saturation current flows (ideally no current should flow). If the reverse voltage is increased continuously, the junction breaks down and suddenly a large reverse current flows. This reverse current is controlled or limited by connecting a suitable series resistance so that excessive heat produced due to heavy current flow may not burn the diode. If the reverse breakdown current is limited to the current-carrying capacity of the diode, it can be operated under reverse breakdown condition. The V–I characteristic of the diode under the reverse-biased condition can be made dropping down almost vertically by proper doping of the semiconductor material. A diode with a very sharp breakdown voltage is called a zener diode.

There are two ways that breakdown of a zenerdiode may occur. One is called zener breakdown and the other is called avalanche breakdown. If the depletion layer of a diode is narrow and we apply a reverse voltage, the voltage per unit of width of the depletion layer becomes high. This establishes a strong electric field intensity which causes electrons to break away from their parent atoms. Thus, a depletion layer which was insulating in nature becomes a conducting path. This kind of breakdown due to the creation of strong electric field intensity, i.e., $V/\mu\text{m}$ is called zener breakdown. If the width of the depletion layer is wide for a zener breakdown, a sufficient reverse voltage may provide the free electrons (minority carriers causing saturation current) to gain sufficient energy to knockout electrons from the atoms of the semiconductor in the depletion region. This is called ionization by collision. The breakdown occurring this way is called avalanche breakdown.

CIRCUIT DIAGRAM:

1. Forward Bias Condition



Bapatla Engineering College::Bapatla (Autonomous)

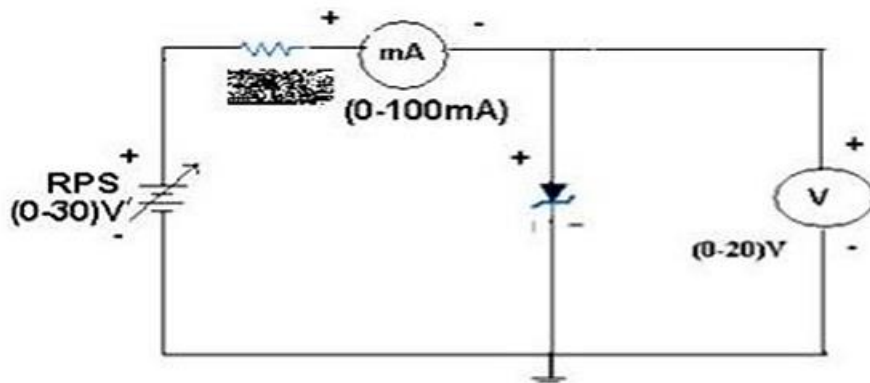

2. Reverse Bias Condition

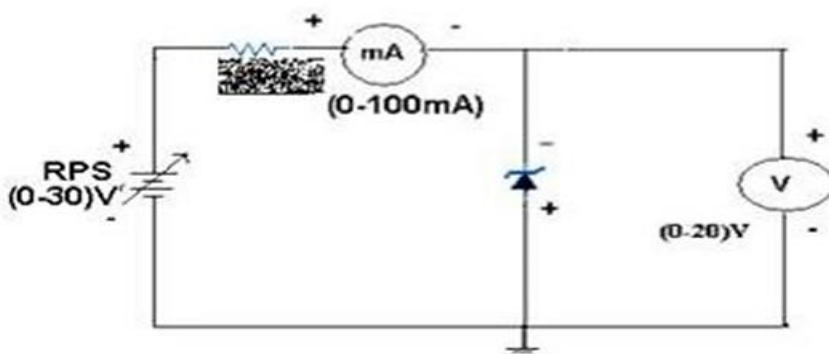

Tabular form for Forward Bias:

S.No.	Applied Voltage(V)	Voltage Across Zener Diode(V)	Zener Diode Current(mA)

Tabular form for Reverse Bias:

S.No.	Applied Voltage(V)	Voltage Across Zener Diode(V)	Zener Diode Current(μ A)



Bapatla Engineering College::Bapatla (Autonomous)

--	--	--	--

V-I Characteristics of ZENER Diode

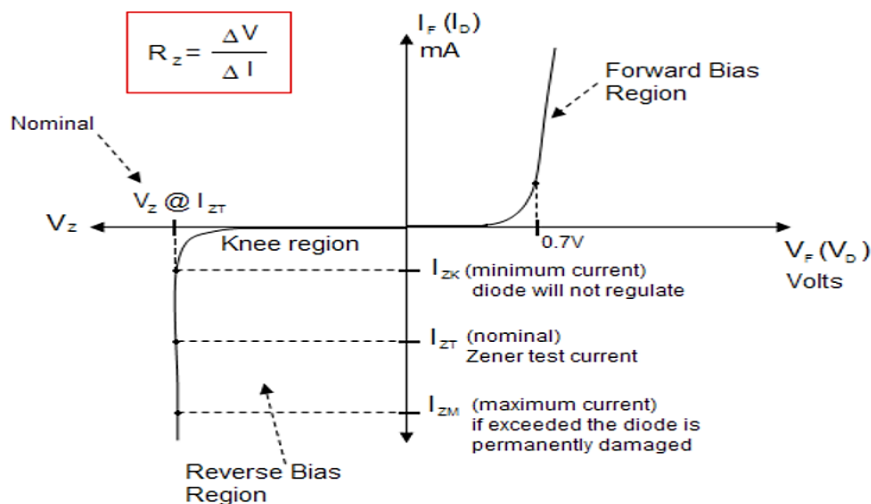

PROCEDURE:

1. Connections are made as per the circuit diagram.
2. The Regulated power supply voltage is increased in steps.
3. The Zener current(I_z), and the Zener voltage(V_z) are observed and then noted in the tabular form.
4. A graph is plotted between Zener current(I_z) and Zener voltage(V_z).
5. Do the above steps for forward as well as reverse bias connections as shown in the circuit diagrams.

Precautions:-

1. The terminals of the Zener diode should be properly identified.
2. Should be ensured that the applied voltages & currents do not exceed the diode rating.

Result: The V-I Characteristics of Zener diode are drawn.



Bapatla Engineering College::Bapatla (Autonomous)

CHARACTERISTICS OFBJT INCOMMON EMITTER CONFIGURATION

AIM: To draw the input and output characteristics of transistor connected in CE configuration.

APPARATUS:

Transistor (SL100orBC107)
RPS (0-30V)
Voltmeter (0-20V)
Ammeter (0-200mA)
Resistors100Kohm, 100ohm
Breadboard and connecting wires.

THEORY:

The emitter is heavily doped, base region is thin and lightly doped and collector is moderately doped and is the largest. The current conduction in transistors takes place due to both charge carriers- that is electrons and holes and hence they are named Bipolar Junction Transistors (BJT). Basic Concepts The operation of the BJT is based on the principles of the pn junction. In the npn BJT, electrons are injected from the forward-biased emitter into the thin base region where, as minority carriers, they diffuse toward the reverse-biased collector. Some of these electrons recombine with holes in the base region, thus producing a small base current, I_B . The remaining electrons reach the collector where they provide the main source of carriers for the collector current, I_C . Thus, if there are no electrons injected from the emitter, there will be (almost) no collector current and, therefore, the emitter current controls the collector current. Combining currents, the total emitter current is given as $I_E = I_B + I_C$. For normal pnp operation, the polarity of both voltage sources must be reversed. When the BJT is used with the base and emitter terminals as the input and the collector and emitter terminals as the output, the current gain as well as the voltage gain is large. It is for this reason that this common-emitter (CE) configuration is the most useful connection for the BJT in electronic systems.

Operation regions and characteristics curves: Depending upon the biasing of the two junctions, emitter-base (EB) junction and collector base(CB) the transistor is said to be in one of the four modes of operation. as described below:

The most important characteristics of transistor in any configuration are input and output characteristics.

A. Input Characteristics: - It is the curve between input current I_B and input voltage V_{BE} constant collector emitter voltage V_{CE} . The input characteristic resembles a forward biased diode curve. After cut in voltage the I_B increases rapidly with small increase in V_{BE} . It means that dynamic input resistance is small in CE configuration.



Bapatla Engineering College::Bapatla (Autonomous)

It is the ratio of change in V_{BE} to the resulting change in base current at constant collector emitter voltage. It is given by $\Delta V_{BE} / \Delta I_B$

B.Output Characteristics: - This characteristic shows relation between collector current I_C and collector voltage for various values of base current. The change in collector emitter voltage causes small change in the collector current for the constant base current, which defines the dynamic resistance and is given as $\Delta V_{CE} / \Delta I_C$ at constant I_B . The output characteristic of common emitter configuration consists of three regions: Active, Saturation and Cut-off.

Active region: In this region base-emitter junction is forward biased and base-collector junction is reversed biased. The curves are approximately horizontal in this region. Saturation region: In this region both the junctions are forward biased. Cut-off: In this region, both the junctions are reverse biased. When the base current is made equal to zero, the collector current is reverse leakage current I_{CEO} . The region below $I_B = 0$ is the called the cutoff region.

CIRCUIT DIAGRAM:

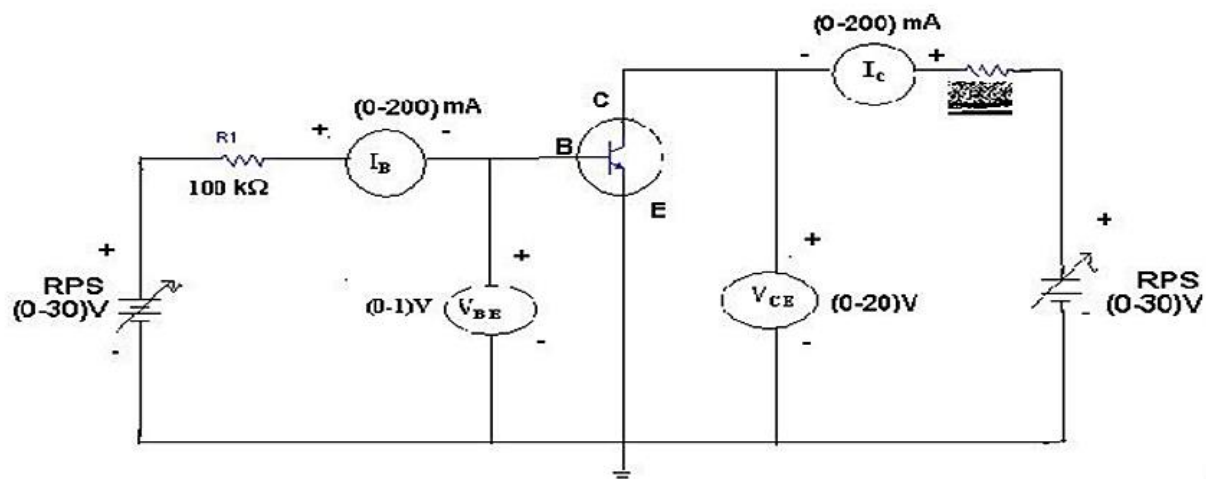

PROCEDURE:

Input Characteristics:

1. Connect the circuit as per the circuit diagram.
2. For plotting the input characteristics the output voltage V_{CE} is kept constant at 1V and for different values of V_{BE} . Note down the values of I_C
3. Repeat the above step by keeping V_{CE} at 2V and 4V.



Bapatla Engineering College::Bapatla (Autonomous)

4. Tabulate all the readings.

5. Plot the graph between V_{BE} and I_B for constant V_{CE}

Output characteristics:

1. Connect the circuit as per the circuit diagram

2. For plotting the output characteristics the input current I_B is kept constant at $10\mu A$ and for different values of V_{CE} note down the values of I_C

3. Repeat the above step by keeping I_B at $75\mu A$ $100\mu A$

4. Tabulate all the readings

5. Plot the graph between V_{CE} and I_C for constant I_B .

Tabular Form: Input characteristics:

S.NO	$V_{CE} = 1V$		$V_{CE} = 2V$		$V_{CE} = 4V$	
	$V_{BE}(V)$	$I_B(\mu A)$	$V_{BE}(V)$	$I_B(\mu A)$	$V_{BE}(V)$	$I_B(\mu A)$

Tabular Form: Output characteristics:



Bapatla Engineering College::Bapatla (Autonomous)

S.NO	$I_B = 50 \mu A$		$I_B = 75 \mu A$		$I_B = 100 \mu A$	
	$V_{CE}(V)$	$I_C(mA)$	$V_{CE}(V)$	$I_C(mA)$	$V_{CE}(V)$	$I_C(mA)$

Precautions:

1. The supply voltage should not exceed the rating of the transistor
2. Meters should be connected properly according to their polarities.

Result : The input and output Characteristics of transistors in CE configuration are drawn.